

FIREBIRD

HEATING SOLUTIONS

CONDENSING BOILER TECHNICAL MANUAL



This manual must remain with the householder once installation is complete

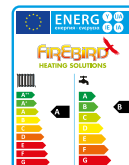
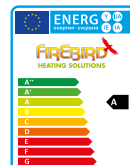

ENVIRONMENT

INNOVATION

TECHNOLOGY

	PAGE
1. FOREWORD & INTRODUCTION	3
2. SAFETY	4
3. STANDARDS & REGULATIONS	5
3.1 Condensate Disposal	6
3.2 Flue Regulations	9
3.3 Flue Systems	12
3.4 Ventilation & Combustion Air Requirements	14
3.5 Liquid Fuel Supply	15
4. SYSTEM CONDENSING BOILER	
4.1 End User Information	16
4.2 Installer Guidelines	19
4.3 Technical Details	21
5. SYSTEMPAC CONDENSING BOILER	
5.1 End User Information	24
5.2 Installer Guidelines	25
5.3 Technical Details	29
6. COMMISSIONING	32
7. SERVICING	34
8. TERMS & CONDITIONS OF WARRANTY	35
9. SERVICE RECORD	36

We would like to thank you for purchasing a high efficiency Firebird condensing domestic central heating boiler. This instruction manual is produced for the reference and guidance of qualified installation engineers such as those who are OFTEC registered. EU legislation governs the manufacture, operation and efficiency of all domestic central heating oil boilers. Our boilers and burners are supplied as matched units, tested and approved to OFTEC Standard OFS A100.

Firebird Heating Solutions are full manufacturing members of OFTEC (Oil Firing Technical Association) and are participating in its boiler testing and approvals programme to comply with OFS A100 and EC Efficiency Directive.

You should ensure that all installation, servicing and commissioning works are carried out by a competent person, such as one registered by OFTEC. It should be noted that it is the responsibility of the Installer/ Householder to ensure that the boiler is properly commissioned. Failure to do so may invalidate the boiler warranty.

SERVICING

The boiler requires servicing on an annual basis to ensure it maintains its efficiency, continues to perform reliably and as a regular check on its built-in safety features. It is important that servicing should be conducted by a competent engineer, such as one who is OFTEC trained and registered.

All appropriate OFTEC manuals and BS Standards should be studied and their requirements adhered to and used in conjunction with these instructions. This manual includes a list of some BS Standards and Building Regulations.

OFTEC is conducting training and registration of engineers and this is to be commended, as reading of this manual alone for installation and servicing procedures cannot replace the critical advantage provided by training and years of experience.

Firebird domestic condensing boilers are highly efficient and are all ErP A rated (Energy related Products). They use less fuel and have lower running costs than non-condensing boilers. Because of their increased efficiency they emit less carbon dioxide than non-condensing boilers, which will contribute to efforts to reduce global warming. The incredible efficiency of the Firebird condensing boiler is due to the development of a single boiler unit with two unique heat exchanger units. This gives an exchange surface greater than non-condensing boilers.

This additional surface area increases the amount of heat extracted from the combustion process and thus reduces the heat wasted to atmosphere. So much heat is extracted from the combustion gases that their water vapor element condenses into liquid form, releasing the latent heat that was used to create the vapor in the first place. It is this heat gain that gives the condensing boiler its significant advantage over a non-condensing model. In order to enable this high level of heat extraction to take place, the water in the boiler's heat exchanger must be cooled down to about 55°C or less, this means that the boiler is working at its maximum efficiency

The condensate produced is often mistakenly considered to be highly acidic. In fact the acidity of condensate from a Firebird condensing boiler will be found to be as low, if not lower, than that of vinegar.

The Firebird condensing boiler even when not working in condensing mode will still operate at extremely high efficiencies making it suitable for fitting to an existing heating system without alteration to the radiator sizes.

The burner is factory set for use with Diesel 35 Second Gas Oil. The burner will require commissioning as described in the commissioning section of this manual due to flue configurations and load conditions.

HEALTH & SAFETY INFORMATION

The installer should be aware of his/her responsibilities under the current, local Health and Safety at Work Act. The interests of safety are best served if the boiler is installed and commissioned by a competent, qualified engineer, preferably OFTEC trained and registered. A Building Notice may be required in England and Wales and other parts of the United Kingdom.

Under the Consumer Protection Act 1987 (UK), section 6 of the Health and Safety Act 1974 (UK) and the Safety, Health and Welfare at Work Act 2005 (ROI), we are required to provide information on substances hazardous to health.

INSULATION AND SEALS

Ceramic Fibre, Alumino - Silicone Fibre material are used for boards, ropes and gaskets. Known hazards are that people may suffer reddening and itching of the skin. Fibre entering the eye will cause foreign body irritation. It may also cause irritation to the respiratory tract.

Precautions should be taken by people with a history of skin complaints or who may be particularly susceptible to irritation. High dust levels are only likely to arise following harsh abrasion. Suitable personal protective equipment should be worn where appropriate.

Generally, normal handling and use will not give discomfort. Follow good hygiene practices, wash hands before consuming food, drink or using the toilet.

First Aid - medical attention should be sought following eye contact or prolonged reddening of the skin.

The small quantities of adhesives and sealants used in the product are cured. They present no known hazards when used in the manner for which they are intended.

THIS PRODUCT HAS BEEN DESIGNED TO THE FOLLOWING STANDARDS:

This equipment complies with the Low Voltage Directive 2014/35/EU and Directive 2014/30/EU.

EMC - conformity was demonstrated by meeting the following standards:

BS EN 55014-2: 2015: Electromagnetic Compatibility - Requirements for Household Appliances, Electric Tools and Similar Apparatus - Part 1: Emission

BS EN 55014-1: 2017: Electromagnetic Compatibility - Requirements for Household Appliances, Electric Tools and Similar Apparatus - Part 2: Immunity - Product Family Standard

BS EN 61000-3-2: 2014: Electromagnetic Compatibility (EMC) Part 3-2: Limits - Limits for Harmonic Current Emissions (equipment input current <16 A per phase)

BS EN 61000-3-3: 2013: Electromagnetic Compatibility (EMC) Part 3-3: Limits - Limitation of Voltage Changes, Voltage Fluctuations and Flicker in Public Low-voltage Supply Systems (equipment with rated current <16 A per phase and not subject to conditional connection)

Safety - conformity was demonstrated by meeting the following standards:

EN60335-1: 2012 + A13: 2017: Household and Similar Electrical Appliances - Safety - Part 1: General Requirements

EN60335-2-102: 2006 + A2: 2016: Household and Similar Electrical Appliances - Safety - Part 2-102: Particular Requirements for Gas, Oil and Solid-fuel Burning Appliances having Electrical Connections

SAFETY

Safe use of Diesel. These fuels give off a flammable vapour when heated moderately. Vapour ignites easily, burns intensely and may cause explosion. The vapour can follow along at ground level for considerable distances from open containers and spillages collecting as an explosive mixture in drains, cellars, etc.

Fuels remove natural oils and fats from the skin and this may cause irritation and cracking of skin. Barrier cream containing lanolin is highly recommended together with good personal hygiene and where necessary appropriate personal protection equipment (P.P.E.).

Gas oil may also cause irreversible damage to health on prolonged or repeated skin contact.

Always store fuels in a properly constructed and labelled tank. Always handle fuel in open air or well ventilated space away from sources of ignition and refrain from smoking.

Always drain fuel using a proper fuel retriever, funnel or mechanical siphon. Never apply heat to a fuel tank, container or pipework. Never siphon fuel through tube by mouth.

Avoid inhaling fuel vapour as this can cause light headedness and seriously impair judgement.

FUEL SPILLAGE

1. Switch off all electrical and other ignition sources.
2. Remove all contaminated clothing to safeguard against fire risk and skin damage. Wash affected skin thoroughly with soap and water and remove clothing to a safe well ventilated area and allow to air before cleaning.
3. Contain and smother the spill using sand or other suitable oil absorbent media or non-combustible material.
4. Do not allow fuel to escape into drains or water courses. If this happens, contact the relevant authorities in your area.
5. Consult local authority about disposal of contaminated soil.

FIRST AID

If fuel is accidentally swallowed:

* Seek medical attention immediately.

Do **NOT** induce vomiting.

If fuel is splashed into eyes:

* Wash out with running water for at least ten minutes and seek medical attention.

STANDARDS & REGULATIONS

To ensure the highest standards of installation & safety, it is important that the boiler be installed in compliance with the following regulations where applicable. It is the responsibility of the installer and everyone concerned with any aspect of installation to ensure that all applicable standards and regulations are fully adhered to.

All **CURRENT** editions of the appropriate Building regulations:

AS1691-1985 Domestic Oil-Fired Appliances
-Installation

All requirements of the New Zealand Building Code.

PRE- INSTALLATION CHECKS

The installer should also be aware of his/her responsibilities under The Health and Safety at Work Act. The interests of safety are best served if the boiler is installed and commissioned by a competent engineer, OFTEC trained and registered.

BOILER INSTALLATION:

Other than special considerations for condensate removal and plume dispersal, the installation of Diesel firing condensing boilers is the same as for non-condensing boilers.

For condensing boilers, the same requirements apply for installation with regard to cleaning and flushing and providing inhibitors as are followed for any other boiler. Manufacturers instructions must always be followed.

In addition, the work must comply with OFTEC Installation requirements for oil fired boilers and oil storage tanks.

OFTEC also publish excellent guides including:

- OFTEC Technical Book One - Safe working for oil firing and delivery technicians.
- OFTEC Technical Book Two - Domestic & light commercial servicing and commissioning.
- OFTEC Technical Book Three - Domestic and commercial requirements for oil storage & supply equipment.
- OFTEC Technical Book Four - Oil fired appliance & system installation requirements.

COPIES OF BRITISH STANDARDS MAY
BE PURCHASED DIRECT FROM:

**BSI (Customer Services),
389 Chiswick High Rd., London W4 4AL.
Tel.: +44 (0)345 0869001**

International and EC Standards are
also available from above.

OFTEC PUBLICATIONS ARE AVAILABLE FROM:

**OFTEC, Oil Firing Technical Association,
Foxwood House, Dobbs Lane,
Kesgrave, Ipswich, IP5 2QQ.
www.oftec.org**

This appliance has been manufactured in compliance with AS1690 Domestic Oil Fired appliances Safe Design Code.

This appliance has a current Occupational Safety and Health (OSH) and Environmental Risk Management Association (ERMA) Clean Air Approval number of BUR0801

This appliance and flue system has been tested by CRL Laboratories in New Zealand (**Certificate number 07-41180**) and can be installed to meet the requirements of AS1691-1985 Domestic Oil Fired Appliances Installation.

This includes suitability for zero clearance installation to combustible surfaces.

Please ensure that this appliance and flue system is installed to comply with manufacturers instructions and AS1691-1985 Domestic Oil fired Appliances Installation.

Please ensure that the appliance is bolted to the floor for seismic restraint.

Firebird recommend the use of Firebird coaxial flue systems to achieve room sealed operation. However, conventional flue systems are also suitable.

The installation of this appliance and fuel source will require a building consent from your local council.

THIS APPLIANCE IS TUNED TO RUN ON DIESEL FUEL.

This appliance must be installed by experienced personnel. Failure to install correctly will invalidate the warranty. The warranty does not cover consequential damages.

If you have any queries with this product, please consult:

**Central Heating New Zealand Ltd.,
52 Pilkington Way,
Wigram,
Christchurch 8042,
New Zealand.
Tel: +(0) 64 3357 1233
www.centralheating.co.nz**

3 3.1 STANDARDS & REGULATIONS - CONDENSATE DISPOSAL

Firebird condensing boilers, when in condensing mode, extract more heat from the flue products and the resulting condensate which is mildly acidic, needs to be drained from the boiler via a condensate pipe to the drainage system.

Provision must be made for the removal of condensate from the boiler to an internal soil stack, waste pipe, external soil stack, gully or soak-away, as per BS 6798: 2014.

The condensate trap is provided with the boiler and situated on the front of the boiler (under the cleaning door). This should be checked at regular intervals and cleaned during annual service.

The condensate line should:

- be plastic and have a minimum diameter of 22mm dia.;
- have a fall from the boiler of 1:200 minimum;
- have as few bends as possible to reduce the risk of trapping condensate.

Copper or steel cannot be used.

CONDENSATE PIPEWORK THAT IS EXTERNAL OR IN AN UNHEATED GARAGE SHOULD NOT EXCEED 3 METERS AND SHOULD BE LAGGED WITH WATER PROOF INSULATION TO PREVENT FREEZING.

SYSTEM NO. 1 CONDENSATE TRAP Always prime condensate trap with water.

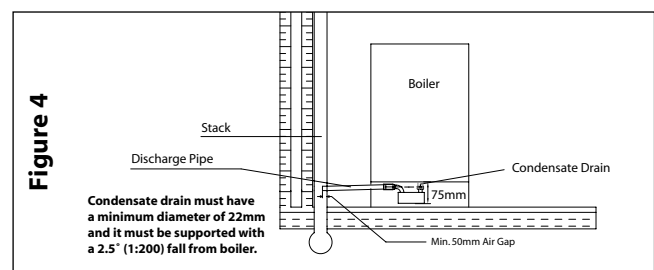
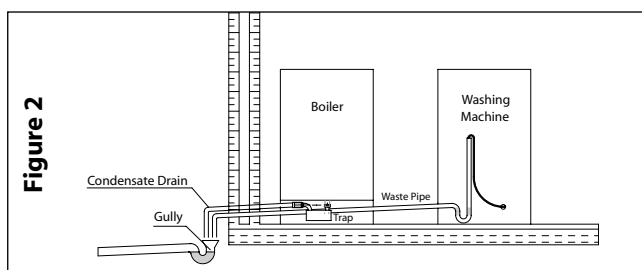
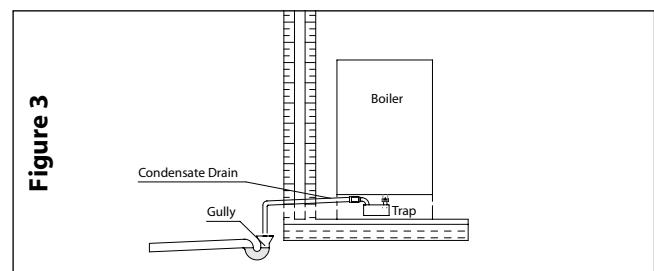
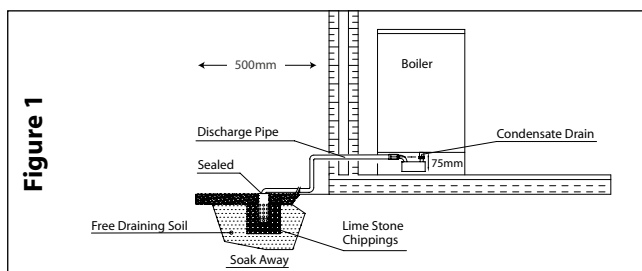
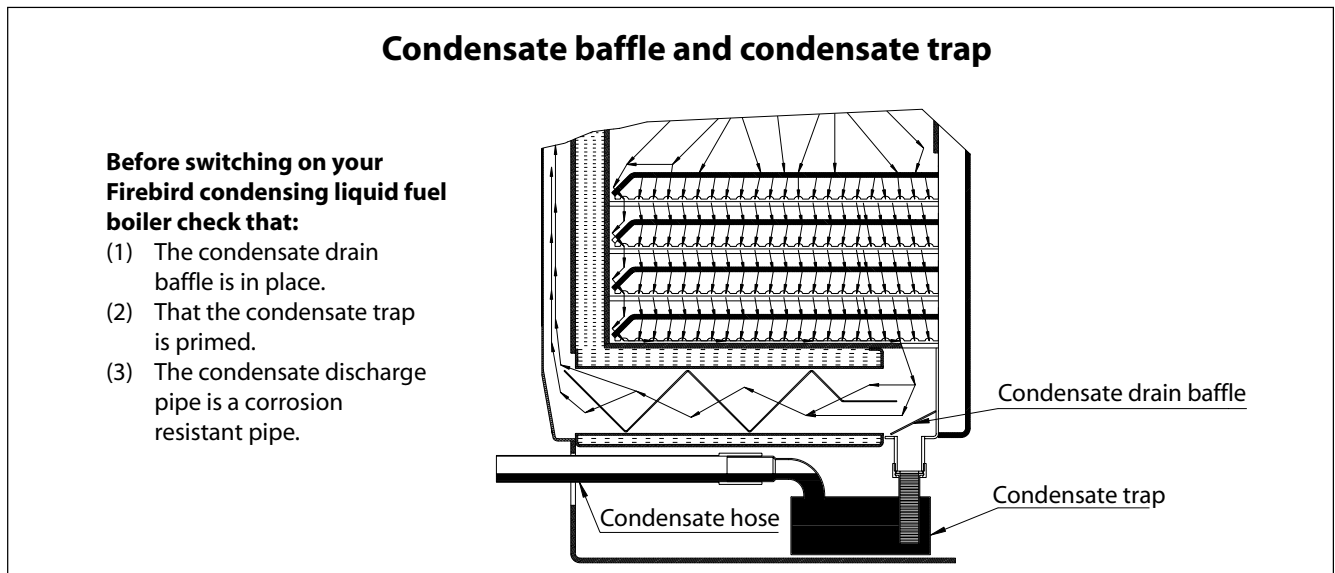

Ensure that the boiler combustion chamber cannot be filled through the condensate trap from another appliance (eg. washing machine) which is drained at a higher level (see Figure 2).

Condensate Trap Fitting

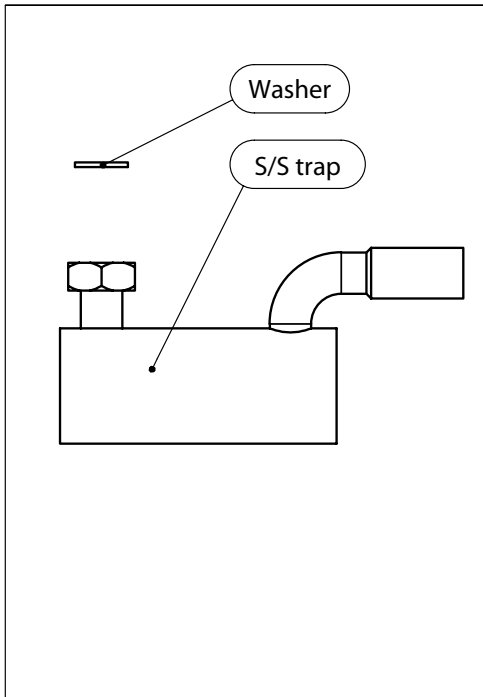

1. Push washer into trap socket and screw trap onto boiler socket.

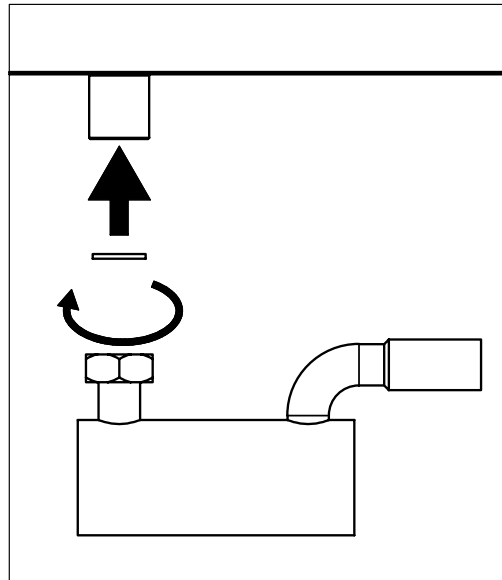

2. Push flexible pipe onto trap socket.

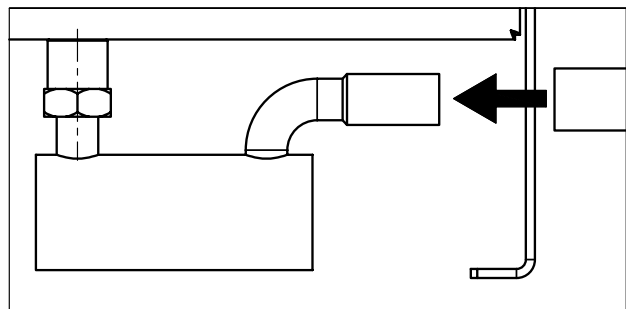

3. Final assembly.

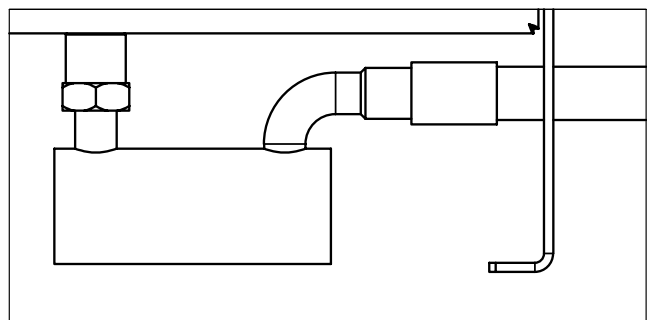

**SYSTEM NO. 2
CONDENSATE PUMP (INDENT ORDER)**

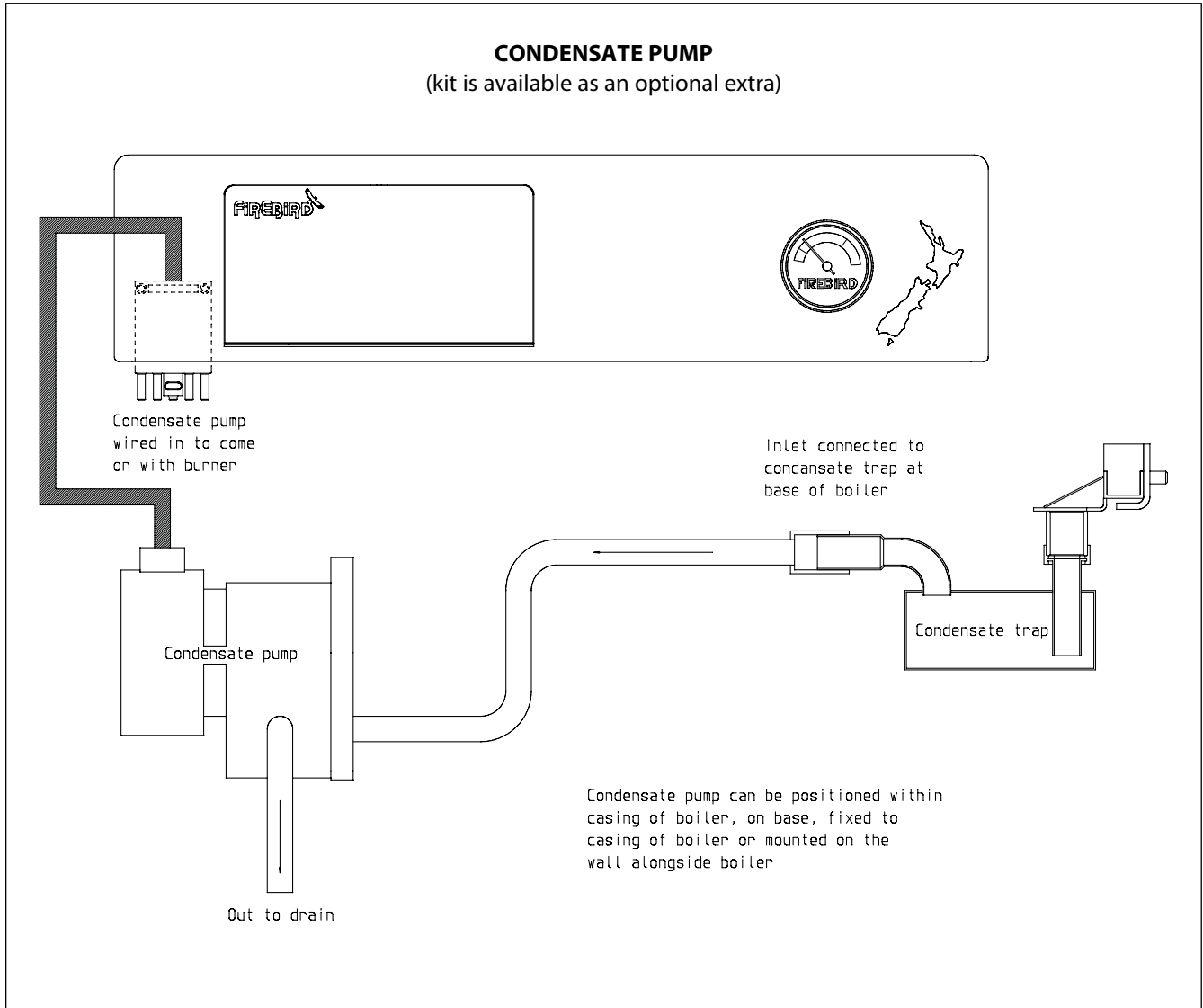

3 3.2 STANDARDS & REGULATIONS - FLUE REGULATIONS

BALANCED FLUE SITING

The terminal should be positioned to avoid combustion products entering the building or accumulating in stagnant pockets around buildings. The terminal must be protected by a guard if it is less than 2 metres above ground level or in a position where any person has access to it (i.e. a balcony). A heat protection shield should be fitted if the terminal is less than 850mm from a plastic or painted gutter or less than 450mm from painted eaves. Prevailing winds should be taken into account when siting a flue.

ALWAYS CHECK FOR ANY BUILDING REGULATIONS AMENDMENTS WHICH MAY HAVE BEEN ISSUED AFTER THE PUBLICATION OF THIS MANUAL

Clearances advised by BS 5410-1: 2014

Regular Appliance (Open, Low Level Discharge and Balanced) Flue Termination Clearance

The basic requirement with regard to flue positioning is that no hazard or nuisance is caused by the flue gases. Diagrams 20a and 20b show clearances advised by BS 5410-1: 2014.

Regional requirements where flue clearances differ can be found in the regional requirements section in OFTEC Book Four.

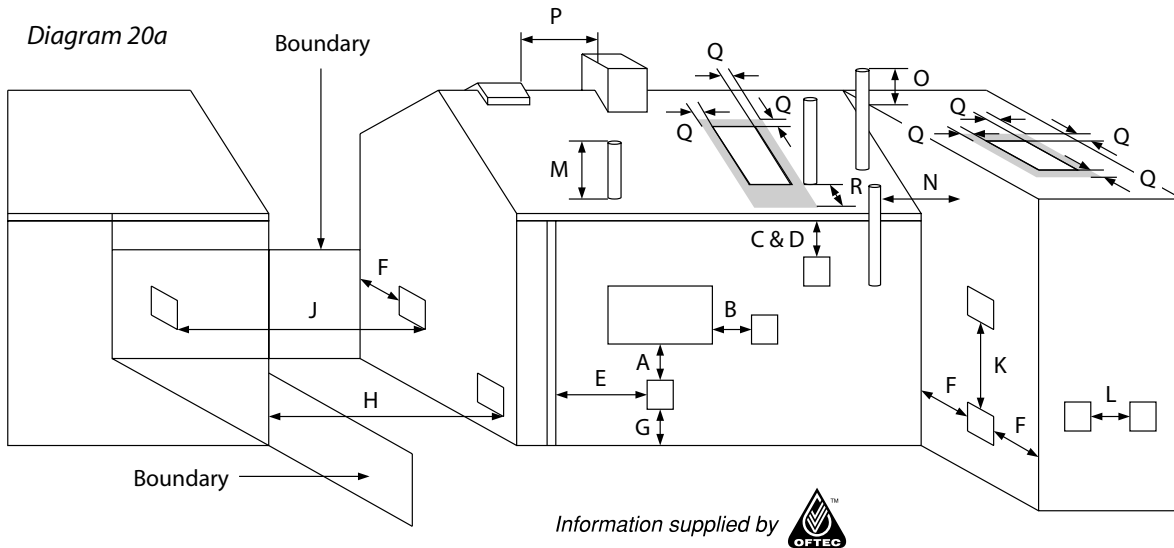

Minimum distances to terminals in millimeters as measured from the top of the chimney or the outer edge of where flue gases pass through low level discharge openings

	Location	Appliance Burner Type	
		Pressure Jet	Condensing
		UK	
A	Directly below an opening, airbrick, opening window etc.	1000mm	1000mm
B	Horizontally to an opening, airbrick, opening window etc.	1000mm	1000mm
C	Below a gutter, eaves or balcony with protection	1000mm	1000mm
D	Below a gutter or a balcony without protection	1000mm	1000mm
E	From vertical sanitary pipe work	300mm	300mm
F	From an internal or external corner or surface or boundary alongside the terminal	300mm	300mm
G	Above ground or balcony level	300mm	300mm
H	From a surface or a boundary facing the terminal	1200mm	1200mm
J	From a terminal facing the terminal	2500mm	2500mm
K	Vertically from a terminal on the same wall	1500mm	1500mm
L	Horizontally from a terminal on the same wall	750mm	750mm
M	Above the highest point of an intersection with the roof	600mm	600mm
N	From a vertical structure on the side of the terminal	750mm	750mm
O	Above a vertical structure less than 750mm from the side of the terminal	600mm	600mm
P	From a ridge terminal to a vertical structure on the roof	1500mm	1500mm
Q	Above or to the side of any opening on a flat or sloping roof	600mm	600mm
R	Below any opening on a sloping roof	2000mm	2000mm

3 3.2 STANDARDS & REGULATIONS - FLUE REGULATIONS

NOTES: These notes form an integral part of the information shown on the previous page.

1. Terminals should be positioned to avoid products of combustion accumulating in stagnant pockets around the building, or entering into buildings.
2. Appliances burning Class D oil have additional restrictions (see OFTEC Book Four).
3. Vertical structures in N, O and P include lift rooms, parapets, dormers etc.
4. Terminating positions A to L are only permitted for appliances that have been approved for low level flue and low level balanced flue discharge when tested to BS EN 303-1.
5. Terminating positions must be at least 1.8m distant from a fuel storage tank unless a wall with at least 30 minutes fire resistance and extending 300mm higher and wider than the fuel storage tank is provided between the fuel storage tank and the terminating position.
6. Where a flue is terminated less than 1m away from a projection above it and the projection consists of plastic or has a combustible or painted surface, then a heat shield of at least 750mm wide should be fitted to protect these surfaces.
7. If the lowest part of the terminal is less than 2m above the ground, balcony, flat roof or other place to which any person has access, the terminal must be protected by a guard.
8. Notwithstanding the dimensions given in the diagram and table, a terminal should not be sited closer than 300mm to combustible material.
9. It is essential that a flue or chimney does not pass through the roof within the shaded area shown by dimensions Q and R.
10. Where protection is provided for plastic components, such as guttering, it is essential that this is to the standard specified by the manufacturer of the plastic components.

Diagram 20b

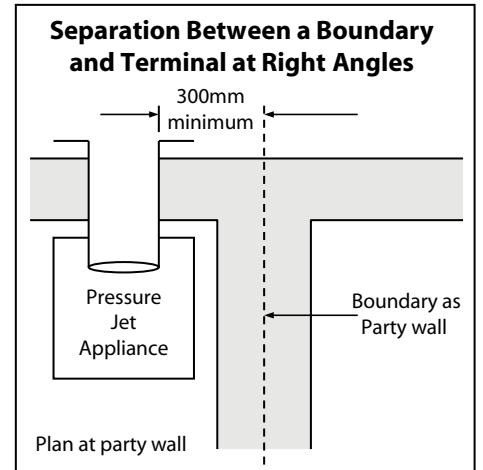

BALANCED FLUE BOILERS

The Firebird boiler may be set for room-sealed flue operation using a Firebird condensing balanced flue kit. This kit does **not** draw **combustion air** from inside the room. **It is drawn from outside, direct to the burner by an air pipe supplied with the boiler.** Flue gases are expelled through the same kit. However, if the boiler is installed in a **compartment** or **small room**, some **ventilation air** is necessary to maintain an acceptable temperature in the boiler area.

Balanced flue boiler in room does not require individual ventilation.

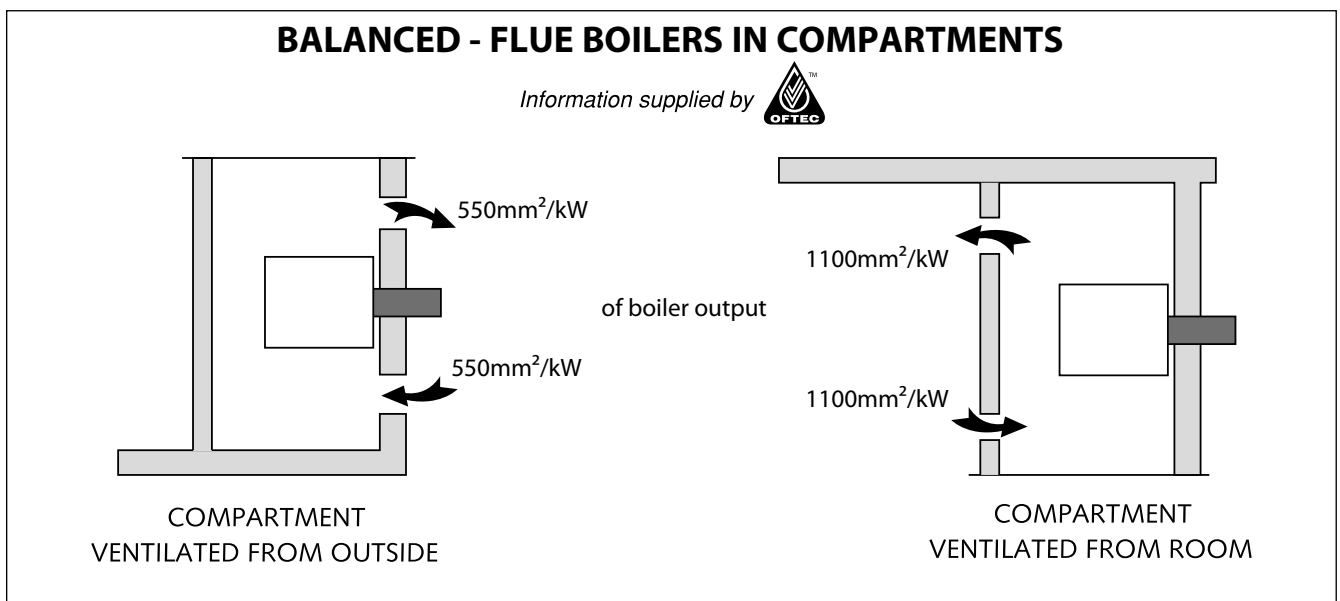

3 3.2 STANDARDS & REGULATIONS - FLUE REGULATIONS

CONDENSATE PLUME DISPERSAL

When choosing the location for a condensing boiler, special consideration must be given to the positioning of the flue terminal. Care should be taken to locate it so as to prevent either the end user or their neighbours perceiving the plume to be a nuisance.

It should be noted that the normal statutory clearances required around low level flue terminals may not be sufficient to cope with plume dispersal from a condensing boiler. The following points should be considered:

1. Plumes can extend out horizontally and can also drift out to the sides and above the terminal. Care needs to be taken, therefore, to avoid the plume reaching adjacent surfaces, particularly windows and neighbours dwellings.
2. Flue terminals need to be located where air can pass freely across them to disperse vapours.
3. The effect of the moisture generated must be considered in relation to the possible corrosion of metal parts it might reach and to the possible formation of ice on pathways in freezing conditions.
4. Keep flue terminals a minimum of 1m (horizontally) from openings in the building.
5. Do not install flue terminals directly below a window.
6. Do not install flue terminals next to a door.
7. Do not install flue terminals within 1m of ventilated soffits or eaves.
8. Keep flue terminals at least 2.5m away from a surface or boundary facing the terminal.
9. In certain circumstances the installation of a plume dispersal extension to the flue may be unavoidable. This takes the plume exhaust from the boiler up and away from any obstruction, door or window opening and will also prevent the risk of re circulation of the plume gasses into the air intake of the burner.

Please note that only Firebird flue kits should be used for flue installations.

CONDENSING BOILER CHIMNEY INSTALLATION

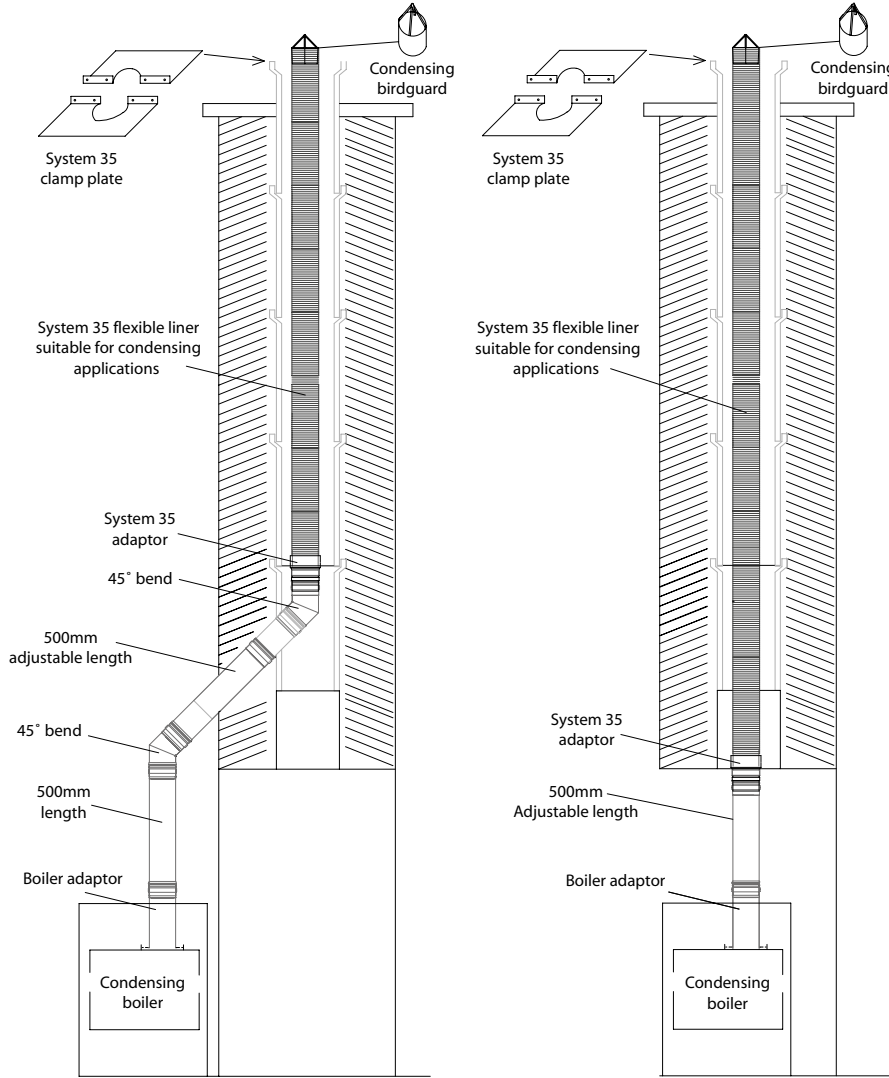

FLUE SIZE

Boiler	Diameter
C26	100mm
C35	100mm

Single wall stainless flue suitable for condensing boilers. Available in stainless steel finish or white finish

NOTE:
All brick chimney constructions must comply with current building regulations and BS 5410-1: 2014. Insulated factory made chimneys should comply with BS EN 1856-1: 2009.

FIREBIRD BALANCED FLUE SYSTEMS

Vertical balanced flue kit - max. flue length 6m.

Low level balanced flue kit - max. length 3m.

High level balanced flue kit - max. length 6m.

Overall length must take into account bends
where 45° bend = 0.5m length and
90° bend = 1m length.

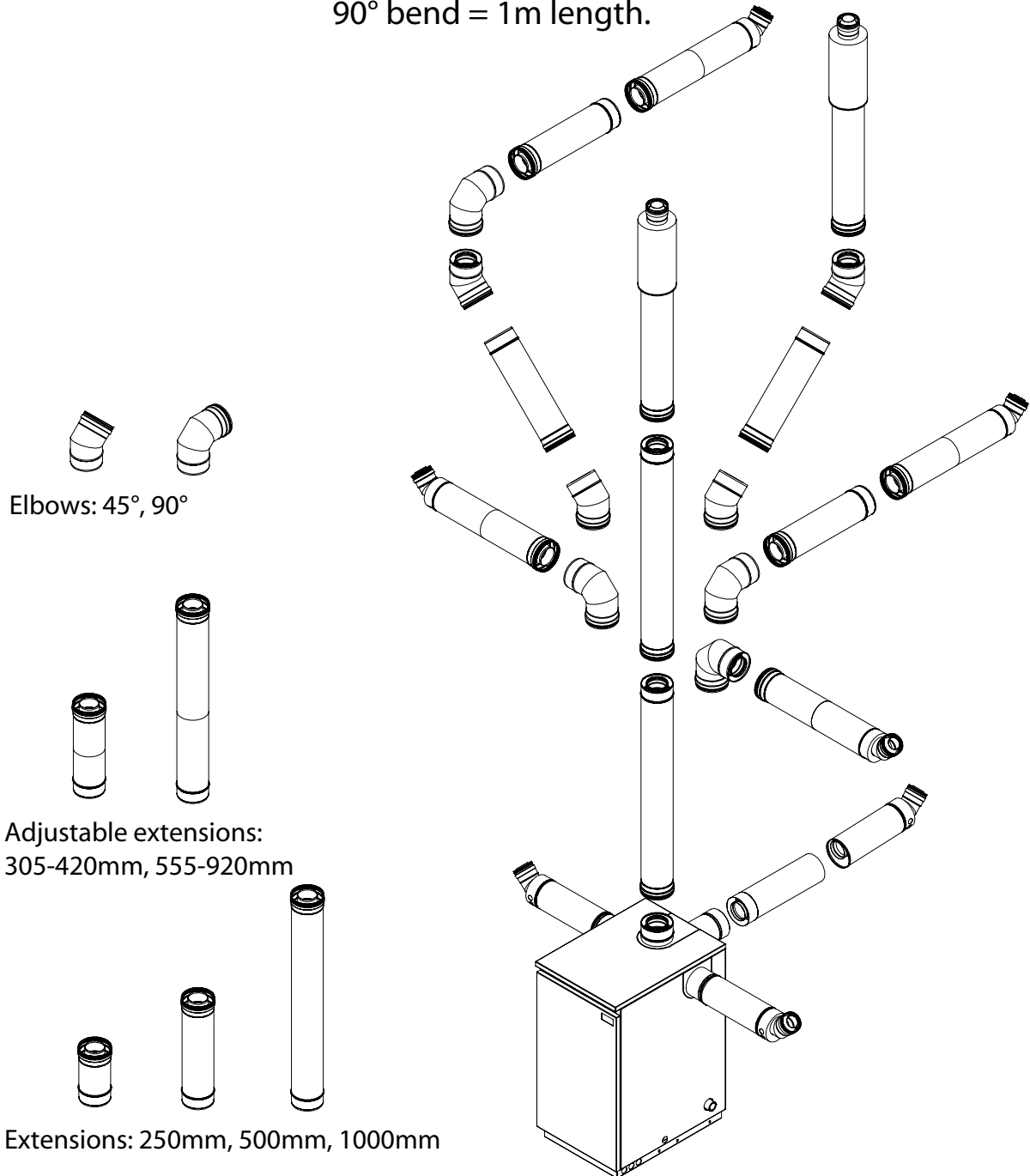

INSTALLATION INSTRUCTIONS SUPPLIED WITH ALL FLUE KITS

LOW LEVEL FLUES

Low level flues installed in a corridor/alley - if the space is less than 3m, a plume kit must be considered. Where there is high risk of funnelling winds. Should the walls either side of the alley be high, again, a plume kit should be considered.

Low level flues installed in open area/garden - avoid facing the flue into the prevailing wind. The flue should face away from prevailing winds.

Please refer to site location sketches for outline of points above. A boiler that fails to operate correctly may require a plume kit. This is because the flue gases are not able to disperse, causing the photocell to become dirty.

ITEMS TO BE CHECKED IN ALL CASES WHERE A BOILER IS OF CONCERN

There are four checks that must always be made where a photocell has stopped a burner:

1. Ensure that the gasket door is sealed correctly to the boiler.
2. Ensure that the burner collar is in place. If you see that the burner collar and surrounding area is getting black, this is highlighting that the boiler is experiencing down draught and requires resealing.
3. A common fault can be that the installer has not placed the receiving nut for the burner on the boiler. If this nut is missing, then the burner sits incorrectly on the boiler.
4. Ensure the flue is attached securely to the boiler, all seals are in place and telescopic flues are not extended beyond the maximum length.

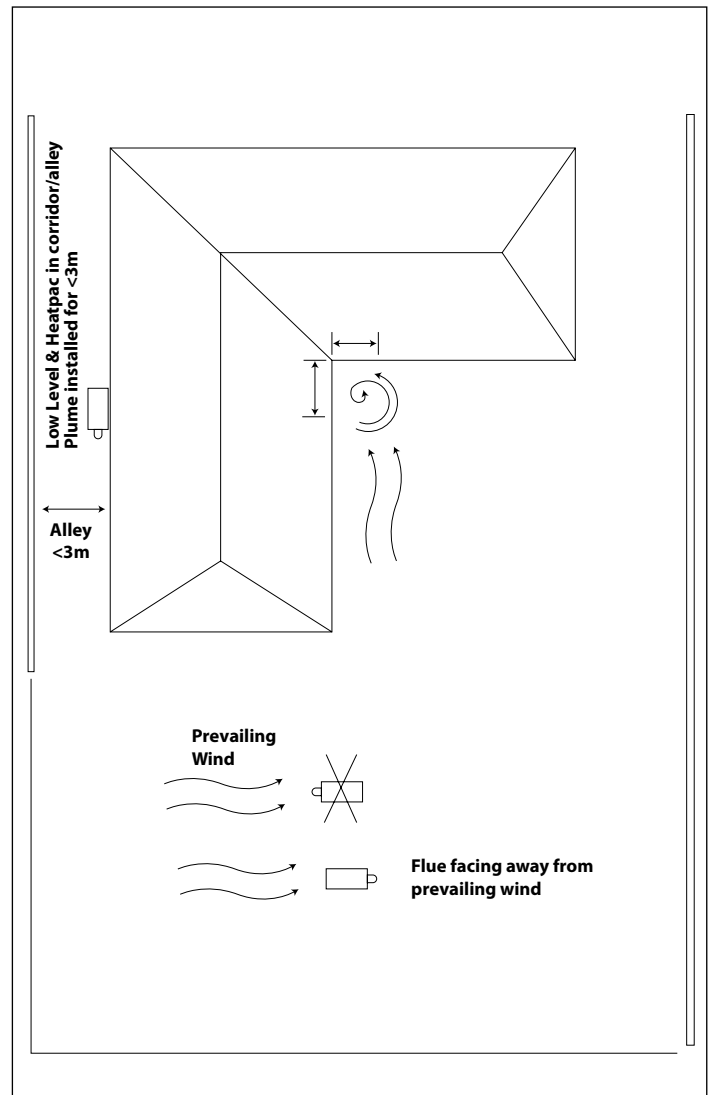
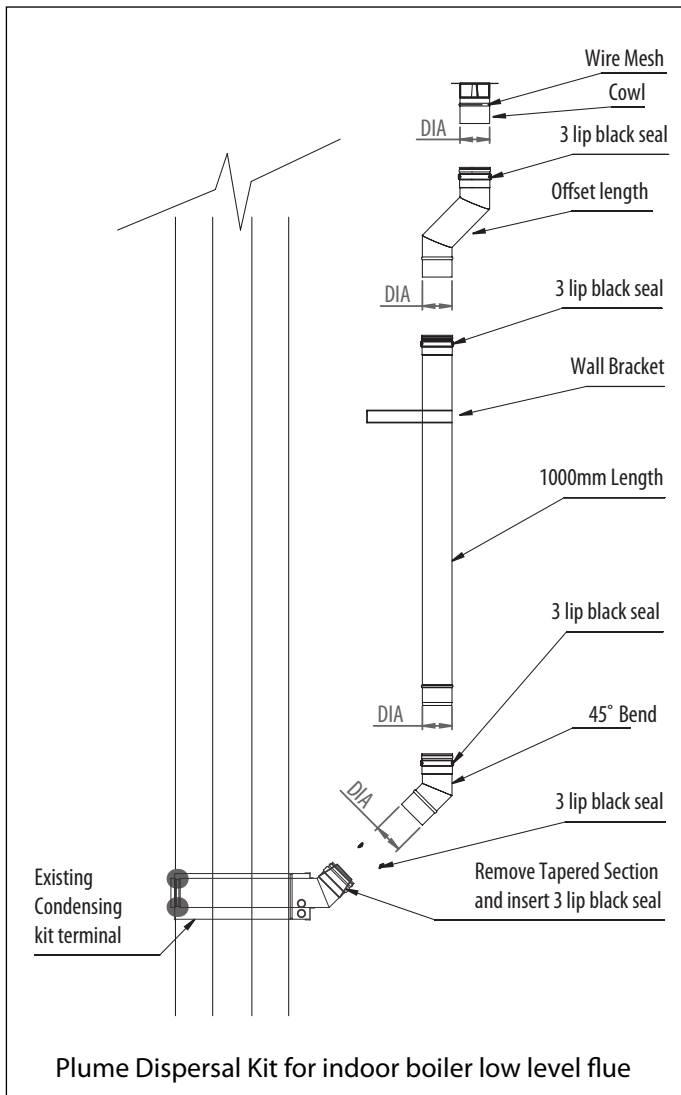

3 3.5 STANDARDS & REGULATIONS - LIQUID FUEL SUPPLY

DIESEL STORAGE TANK SITTING

Consult OFTEC Manuals

It is unlikely that a fire will start at a Diesel tank. However, the stored diesel must be protected from a fire or heat source that originates nearby. For this reason fuel tanks of up to 3,500 litres should be separated from openings, other than airbricks, in the building by a minimum of 1.8m and a non-fire rated boundary by a minimum of 760mm. Where this cannot be achieved, a 30 minute fire rated barrier should be constructed between the hazard and the tank, which extends a minimum of 300mm higher and 300mm past each end of the tank. Note that a minimum separation distance should be maintained between a flue exit and fire barrier (see flue regulations).

Steel tanks must be mounted on brick or block piers with a waterproof membrane between the piers of the tank.

Diesel storage tanks should not be sited within 1.8m of boiler flue outlets.

Do not allow household waste or hot ashes container in vicinity of oil storage tank or boiler flue outlet.

FLEXIBLE OIL PIPE(S)

Two flexible burner Diesel hoses are supplied with the boiler which must be wholly contained within the appliance case.

Please note: A filter must not be fitted inside the boiler and all joints in the oil line must be oil tight. Soldered joints are not permissible. Before connecting to the boiler, always flush the complete oil supply line and ensure that the liquid fuel supply is completely clean and free of any dirt or foreign matter.

SINGLE PIPE SYSTEM

A T piece is supplied when the burner is set up for two pipe operation in order to pipe into a one pipe system.

OIL LINE CONFIGURATION

Refer to burner manual section on Hydraulic Systems for:

- Two pipe systems.
- Pipe sizing & distance.
- Tank heights.
- Pump priming.

REGULATIONS & STANDARDS

Please consult all local and regional regulations, relevant to water resources (control of pollution and oil storage) as well as OFTEC Book Three.

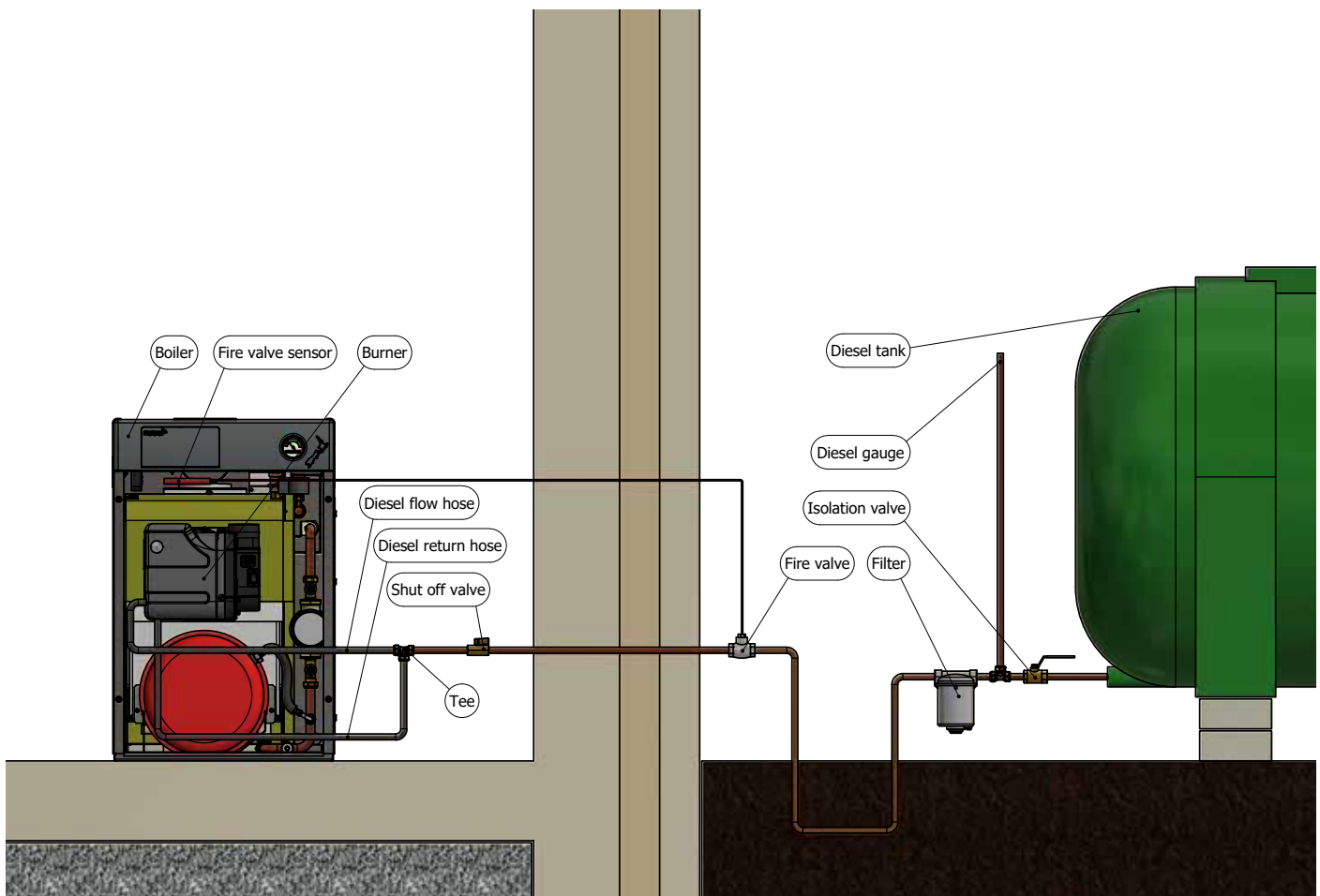

4 4.1 SYSTEM CONDENSING BOILER - END USER INFORMATION



BOILER THERMOSTAT/THERMISTOR FUNCTION

The control thermostat on the boiler allows the householder to vary temperature to central heating from a low of 60°C to 80°C, depending on the model.

This boiler is also fitted with a safety high limit thermostat, fixed at 110°C. This system protects the boiler in the event of the control thermostat failing and keeps the boiler safe.

The safety high limit thermostat will shut the boiler off and will require the limit button to be pushed to restart the boiler. It is recommended to call a service engineer to establish the cause.

BURNER LOCKOUT

The boiler is factory fitted with a burner control box lockout safety feature which operates automatically if a fault occurs in the burner operation. Should this occur, the light on the front of the burner will illuminate.

Press the reset button a maximum of two times. If the boiler fails to light, call a service engineer who should check the following:

- A. An interruption in the fuel supply (eg. empty fuel supply tank).
- B. An electrical supply fault.
- C. A fault with the burner or its safety control system.
- D. The failure of a burner component.
- E. Worn or dirty fuel nozzle.
- F. Incorrect flue installation.

To restart the boiler:

1. Press reset button.
2. Ensure that the boiler thermostat, time switch (if fitted) and any external controls connected to the boiler are set to call for heat.
3. Check that the oil supply valves are open and that there is sufficient oil in the tank.
4. Check that the main power supply is on. The boiler is now ready.

To start the boiler:

- Turn on fuel supply.
- Switch on power supply to boiler.
- Turn timer control (if fitted) to "ON".
- Set the boiler thermostat to the required temperature. The boiler thermostat controls the boiler operation by automatically maintaining the required boiler water temperature output. Safe operation is also maintained by the burner control system which provides the required ignition and shut off sequence. If the optional timer control is fitted, this will automatically switch the boiler off and on when heat is required.

To turn off the boiler:

- Turn the timer control (if fitted) to "OFF".
- Turn off the mains electrical supply to the boiler.

4 4.2 SYSTEM CONDENSING BOILER - INSTALLER GUIDELINES

Please note the following important points before commencing installation.

Installation should only be carried out by a competent, qualified engineer, preferably OFTEC registered, familiar with the installation of the Firebird boilers referred to in this manual.

WARNING

The manufacturer cannot accept responsibility for any damage to persons, animals or property due to error in installation or in the burner adjustment or due to improper or unreasonable use or non-observance of the technical instruction enclosed with the burner, or due to the intervention of unqualified personnel.

POSITIONING THE BOILER

In order to comply with the terms and conditions of warranty, when installing a boiler on a new or existing system, the system should be cleaned, flushed and then protected with a suitable protection inhibitor.

Ensure that adequate clearance is available for making the water and flue connections.

The boiler is serviced from the front and a clearance of 750mm must be available at the front of the boiler.

No special hearth is required as the boiler is fully insulated, but the floor must be level and capable of supporting the weight of the boiler and its water content.

Sound levels must also be a consideration. Whilst Firebird condensing liquid fuel boilers are one of the quietest boilers on the market, some householders are particularly sensitive.

A suitable corrosion inhibitor must be added to the heating system.

UNDERFLOOR HEATING

The boiler should not be directly connected to underfloor heating, as a minimum return temperature of 40°C is required (it can be used with underfloor heating with adequate temperature controls to ensure return values are as stated above).

PLASTIC PIPING

The boiler thermostat control and safety system is not designed, and must not be relied on, to protect plastic pipe from overheating. Additional measures must be incorporated into the system pipework for protection in these circumstances. Plastic pipe must never be connected directly to the boiler and there must be at least 1 meter of copper pipe between the boiler and the first plastic connection. If you choose to use plastic pipe anywhere on your heating circuits, please consult the plastic pipe manufacturer for their instruction on how to ensure their product never overheats. Our boiler control and safety high limit thermostats are not designed to fulfil this function.

Firebird accepts no responsibility for failure of plastic piping and fittings for whatever reason.

PRESSURISED HEATING SYSTEM

Normal cold pressure should be set at 1 bar. The maximum operating working pressure is 2 bar when the system is at full operating temperature.

EXPANSION VESSEL

Total water content of system and boiler must be calculated to determine if an additional pressure vessel is required.

MAGNETIC FILTRATION

It is recommended at the time of installation of this boiler, to install a permanent effective magnetic filter on the return pipework after the last radiator on the central heating system. This will maintain maximum operational efficiency and protect the boiler from the damaging, long-term effects of "magnetite" (black iron sludge). It is essential that the filter is sized similar to the return pipework. The magnetic filter must be installed in accordance with the manufacturer's instructions and serviced annually.

HARD WATER - LIMESCALE

On initial fill, where it is suspected that there is a high concentration of scale products, a suitable inhibitor must be used to protect the boiler and system. Check with local water authorities if in doubt (max. 200 ppm).

BURNER

The burners is factory set for use with Diesel 35 Second Gas Oil.

4 4.2 SYSTEM CONDENSING BOILER - INSTALLER GUIDELINES

PIPEWORK

Do not obstruct flue fitting with pipework.
Connect pipework as shown below.

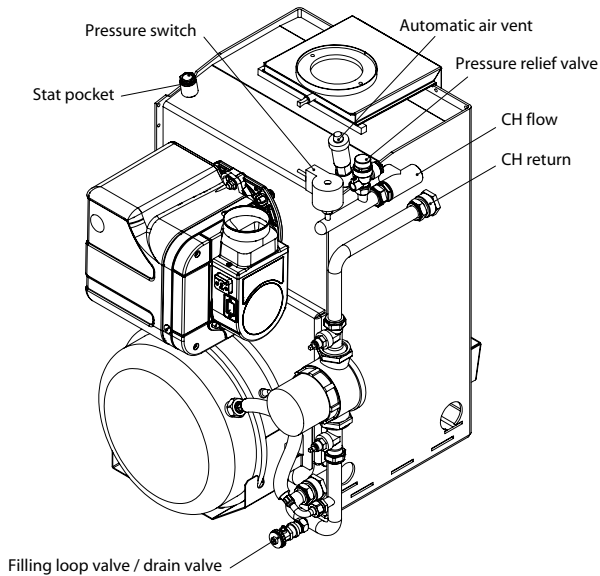

SEALED HEATING CIRCUIT

The system must comply with BS 7074 Part 1 and BS 5449 Part 1 with a maximum water temperature of 80°C.

- * A manual reset overheating limit thermostat is located at the rear of the electrical control panel. If a boiler overheating condition arises the burner will stop and remain inoperative until this thermostat reset button is pressed.

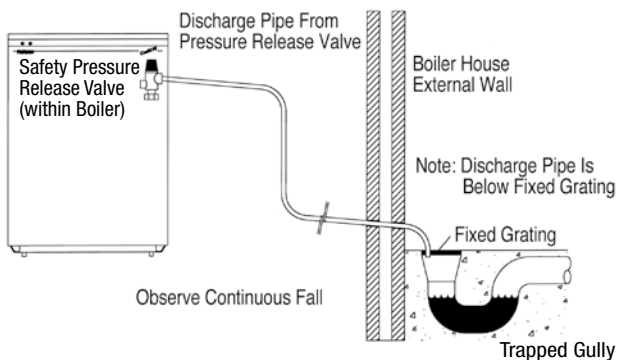

- * A pressure release valve to BS 6759 operating at 3 bar is fitted. A discharge pipe of 15mm diameter is also fitted to the discharge connection on the pressure release valve. During installation an extension pipe should be fitted to this, leading to outside the building. The pipe should be as short as possible and may need a tundish fitted in a protected position within the building.

Note: Water must not discharge above an entrance, window or where public have access. The installer must be aware that the discharge may be boiling water.

- * A pressure gauge with a 0 to 4 bar range is fitted to the boiler control panel. This indicates water pressure in the boiler and system at time of reading. **Pressure when cold should be 1/2 bar minimum to 1.5 bar maximum.** This is known as Initial System Design Pressure (P_i).

N.B. Initial System Design Pressure (measured in bar) equals static head of system (measured in bar) plus 0.3.

SEALED HEATING CIRCUIT

The system must comply with BS 7074 Part 1 and BS 5449 Part 1 with a maximum water temperature of 80°C.

- * A manual reset overheating limit thermostat is located at the rear of the electrical control panel. If a boiler overheating condition arises the burner will stop and remain inoperative until this thermostat reset button is pressed.



When the system is cold and filled to initial fill pressure P_i the pointer on the pressure gauge should point to **1 bar**. The pressure gauge shown has **two red zones** marked on it. The first is between 0 and 1/2 a bar. If the pointer falls into this zone when the system and boiler are cold, this indicates that the initial System Fill Pressure has dropped and this will activate the pressure switch cutting off power supply to the boiler. Refill system manually until indicated pressure rises to 1 bar.

N.B. Insufficient pressure in the boiler will cause the power supply to switch off.

- * A 12 litre expansion vessel is fitted to the boiler, precharged with air or nitrogen to **1 bar** which allows a system static head of 5 metres. If the static head is greater than this then the air charge in the vessel must be increased to balance the higher static head. **The air charge should not exceed a pressure of 1.5 bar.**

If the static head is altered, then it is also necessary to alter the air charge pressure to equal the static head (+ 0.3 bar). This is necessary in order to keep the system water from entering the expansion vessel until the system is being heated and thus allow its maximum acceptance volume (V) to be used **only to accommodate the expansion of system water during boiler operation.**

4 4.2 SYSTEM CONDENSING BOILER - INSTALLER GUIDELINES

Remember that air charge pressure **must** be **equal** in both vessels (attached to the same system). In the above example this is 1 bar. **Air charge pressure** is the air pressure in the expansion vessel **before** the system is filled. It is measured with a tyre gauge attached to a Schrader valve on the vessel.

N.B. The second **red zone** is between 2.5 and 4 bar pressure. When the heating system is up to full working temperature, if the pointer on the pressure gauge should enter this **red zone** showing a final system design pressure of more than **2.5 bar**, it is likely that:

- Total** system water content is greater than that calculated and if an additional expansion vessel has been fitted, it should be replaced with a larger unit
OR if only an integral boiler expansion vessel is used, then an additional expansion vessel is required.
- Static head may be higher than calculated. In this case it is necessary to re-measure the static head and revise expansion vessel air charge pressure.
- Expansion vessel size is incorrect or the air charge pressure is incorrect.

**Refer to BS 7074
Part 1 and BS 5449 for further information.**

EXPANSION VESSEL AND SYSTEM REQUIREMENTS

Safety Valve Setting	3 bar		
Initial System Pressure	0.5 bar	1.0 bar	1.5 bar
Total Water Content of System	Total Vessel Volume **		
Litres	Litres	Litres	Litres
25	2.1	2.7	3.9
50	4.2	5.4	7.8
75	6.3	8.2	11.7
100	8.3	10.9	15.6
125	10.4	13.6	19.5
150	12.5	16.3	23.4
175	14.7	19.1	27.2
200	16.7	21.8	31.2
225	18.7	24.5	35.1
250	20.8	27.2	39.0
FOR FURTHER INFORMATION, CONSULT APPROPRIATE TRAINING MANUALS, BS 7074-1: 1989, BS EN 12828: 2012 + A1: 2014 AND ANY OTHER RELEVANT STANDARDS & REGULATIONS.			
* * When calculating the size of any additional expansion vessel, remember to deduct the boiler expansion vessel volume of 12 litres from the calculated total system vessel volume required, as given in the above table.			

EXAMPLE: using above table

If total water content of system is	- 150 litres
and initial system pressure required is	- 1.0 bar
then vessel volume required is <small>[from above table]</small>	- 16.3 litres
The vessel supplied with boiler is	- 12.0 litres
therefore an additional vessel of is required	- 4.3 litres <small>(minimum)</small>

(For this system of 150 litres - total water volume)

The nearest available stock size for the additional vessel required at 1 bar initial system pressure (taken from table), is 5 litres.

It is emphasised that the installer should be fully acquainted with sealed system installation and operation, calculation of total system water volume, determining of initial system pressure required and calculation of any additional expansion vessel volume required. **The warranty is void if the boiler is installed in a system with insufficient expansion.**

NB. Ensure that all expansion vessels in the same system are set at EQUAL air charge pressures.

SYSTEM FILLING, TESTING AND MAKE-UP

Introduction

Mains cold water is supplied through the boiler drain/fill valve.

Heating Circuit

This is the heating system including the boiler which is filled from the mains supply via a flex filling loop to a pressure determined from the system static head, expansion vessel size and system water volume. This flexible filling loop should be disconnected when boiler and system are filled and checked.

NOTE: There shall be no direct connection to the mains, even with the use of a non-return valve without the permission of Local Water Authority.

* It is recommended that an inhibitor be added at the time of final fill to protect the System from corrosion. Ensure that this is carried out in accordance with inhibitor manufacturers instructions. Installer should ensure that inhibitor used is suitable and that it will have no adverse effect on Expansion Vessels diaphragms or any other part or component of the system.

4 4.2 SYSTEM CONDENSING BOILER - INSTALLER GUIDELINES

WIRING

Electrical Supply

The boiler and controls require a 230V 50Hz mains electric supply protected with a 5A fuse.

This appliance must be earthed.

A qualified electrician must carry out all electric wiring in accordance with current ETCI / IET Regulations and any local regulations which may apply.

The boiler must have a permanent power supply to enable overrun and frost protection. The hot water and central heating should be timed separately.

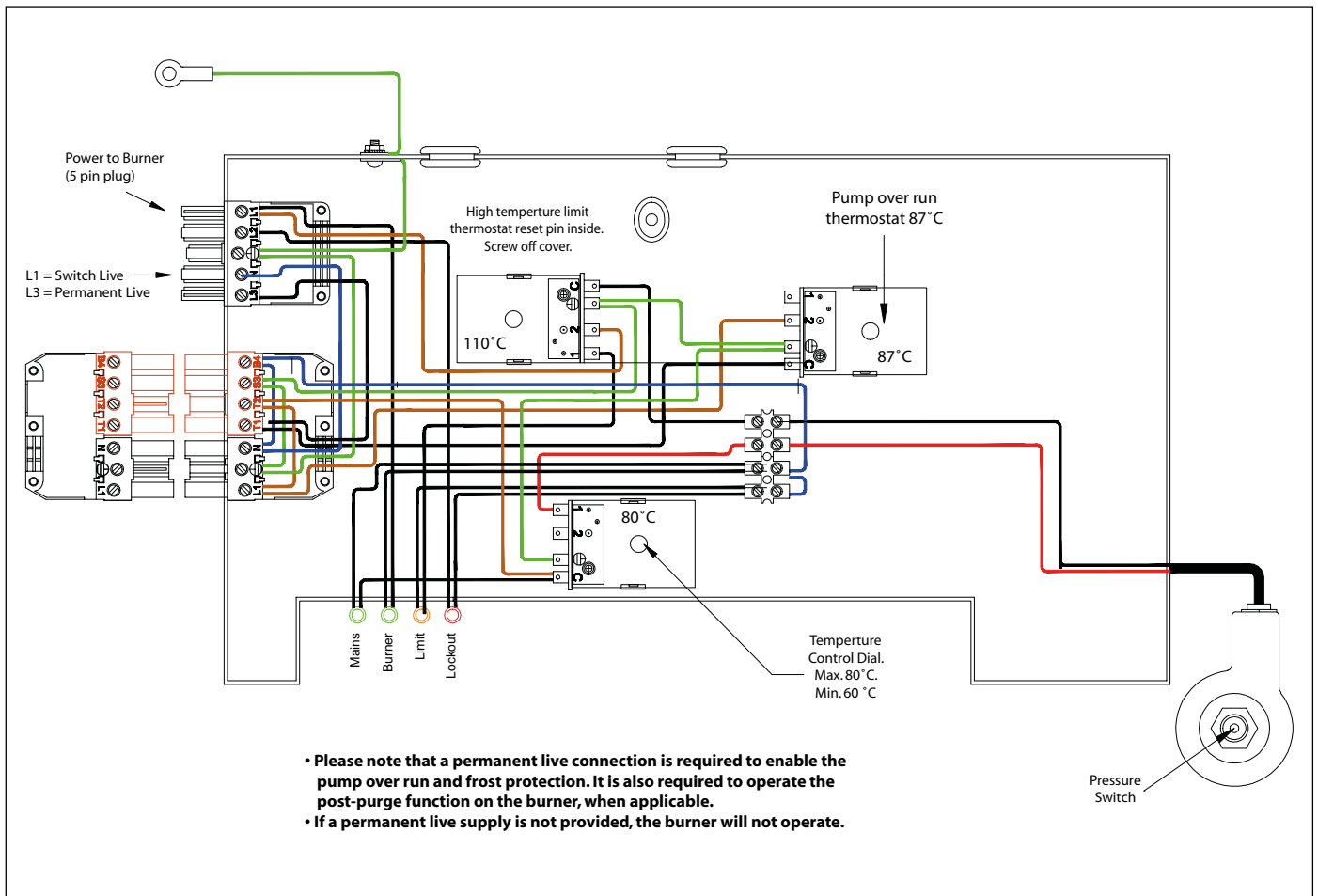

4 4.3 SYSTEM CONDENSING BOILER - TECHNICAL DETAILS

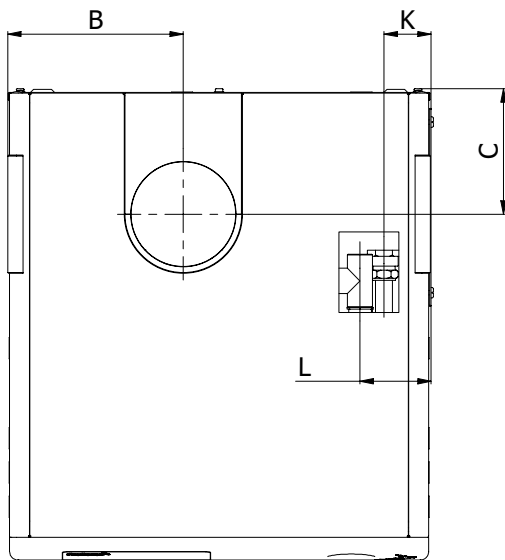
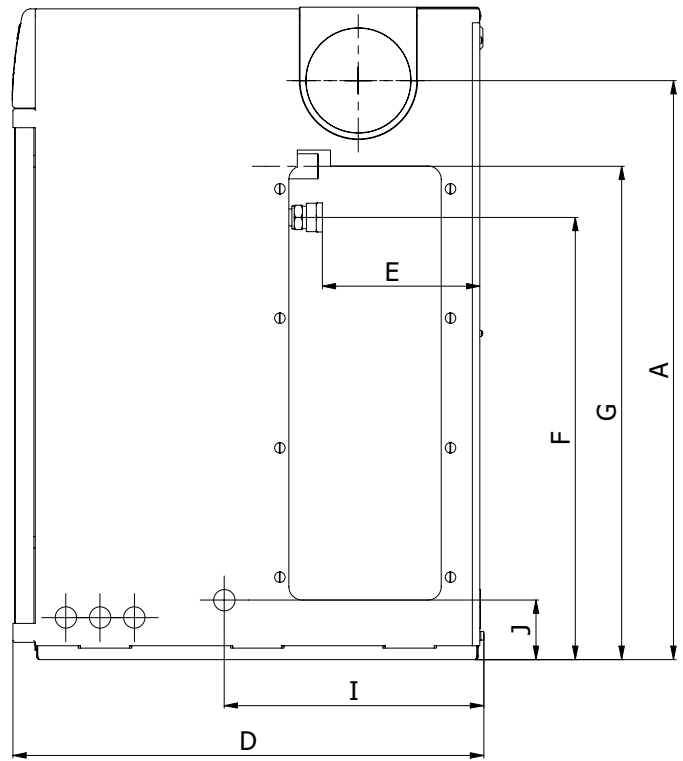
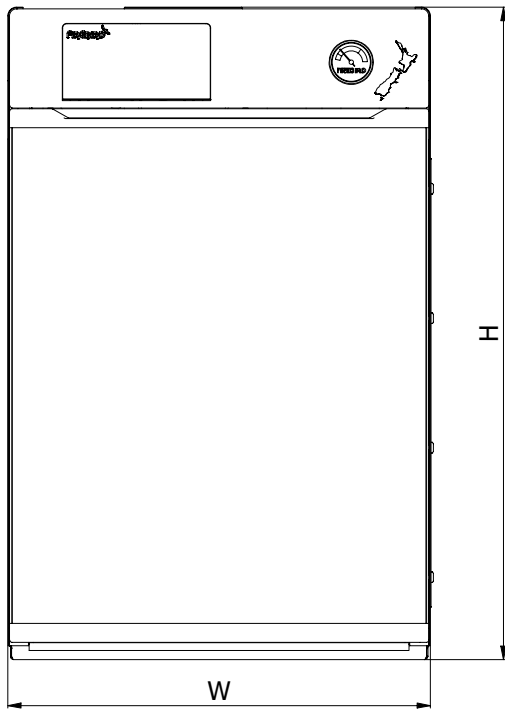

Model - System Condensing (output range)	Weight kg	Dimensions (mm)												
		H	W	D	A	B	C	E	F	G	I	J	K	L
C26 System Condensing 26kW	148	856	555	618	760	231	165	210	580	648	341	78	62	93
C35 System Condensing 35kW	151	856	555	618	760	231	165	210	580	648	341	78	62	93

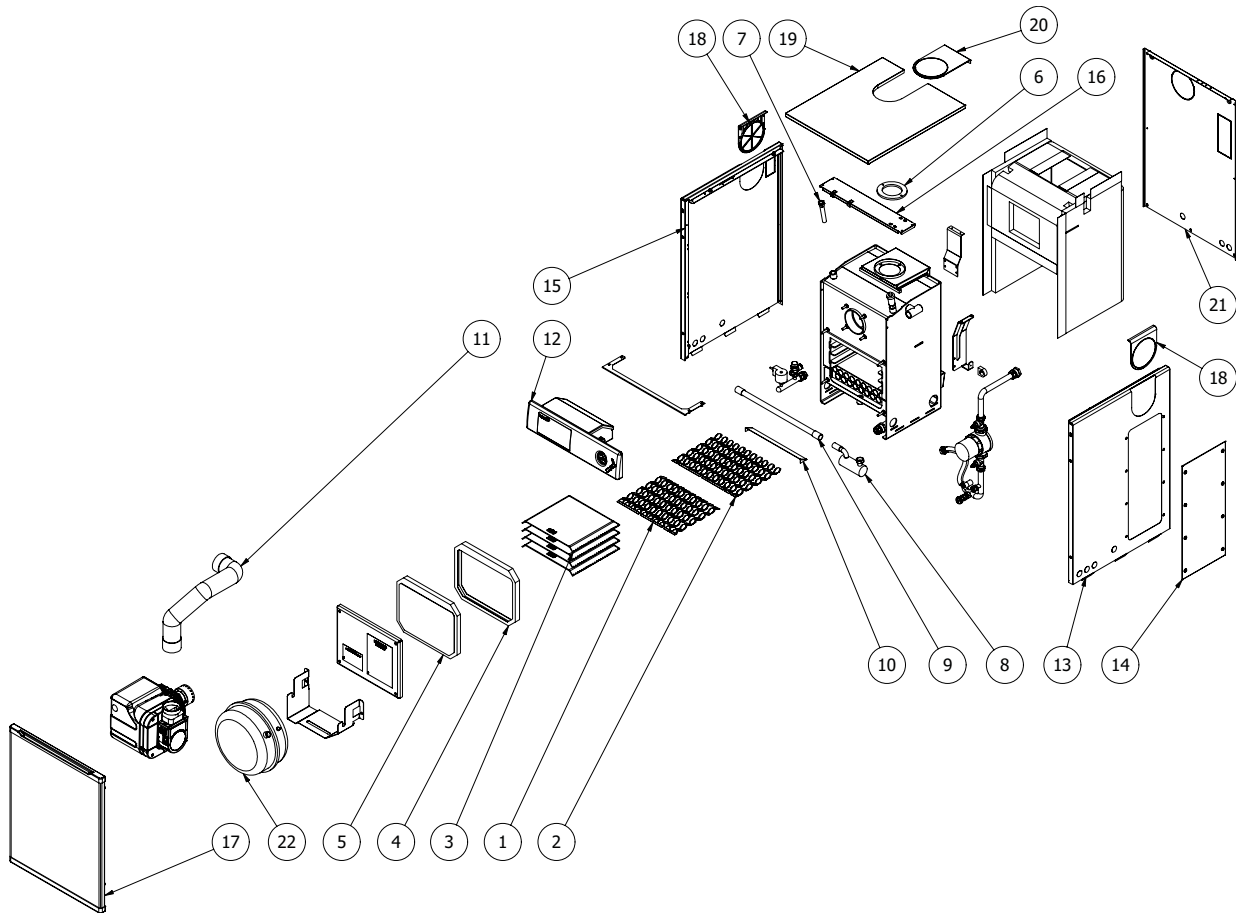

No.	Qty	Description	26 kW	35 kW
1	4	Tube baffle	BA110907	BA110907
2	5	Tube baffle single	BA110908	BA110908
3	4	Smoke baffle	BA212028/BA212122	BA212028/BA212122
4	1	Door seal	ACC035GRA	ACC035GRA
5	1	Door duroboard	ACC035GSK	ACC035GSK
6	1	Flue gasket	ACC000FRG	ACC000FRG
7	1	Stat pocket	ACC003PKT	ACC003PKT
8	1	Condensate trap	ACC000TRP	ACC000TRP
9	1	Condensate hose	ACC000FLX	ACC000FLX
10	1	Heat deflector	ACC000HTD	ACC000HTD
11	1	Air hose	ACC000SSH	ACC000SSH
12	1	Control panel	314734	314734
13	1	Casing left side	214744	214744
14	1	Casing side cover	214748	214748
15	1	Casing right side	214745	214745
16	1	Casing top support	214749	214749
17	1	Casing front	214746	214746
18	2	Side flue blank	114729 + 114730 + 114731	114729 + 114730 + 114731
19	1	Casing top	214750	214750
20	1	Top flue blank	114728+114729+114730	114728+114729+114730
21	1	Casing back	214747	214747
22	1	Pressure vessel	ACC012PVL	ACC012PVL

HEAT OUTPUT	kW	26	35
CONNECTIONS		-	-
Heating Flow		22 mm dia.	28 mm dia.
Heating Return		1" BSP	1" BSP
Mains Cold Feed (Copper)		15 mm dia.	15 mm dia.
Drain Off Valve		½" BSP	½" BSP
Safety Pressure Valve Outlet (Copper)		15 mm dia.	15 mm dia.
Condensate Trap		22 mm dia. plastic pipe	22 mm dia. plastic pipe
CIRCULATING PUMP		25/60	25/60
Integral Expansion Vessel Normal Capacity		12 litres	12 litres
Expansion Vessel Pre-charge Pressure		1 bar	1 bar
Low Pressure Water Switch?		✓	✓
Filling Loop Included?		✓	✓
WATER CONTENT		-	-
Boiler		24 litres	24 litres
FLUE (INDOOR BOILERS)		-	-
Balanced Flue Assembly		125 (5") mm dia.	125 (5") mm dia.
Max. Low Level Flue Length		1.5m	1.5m
Max. High Level Balanced Flue Length		6m	6m
HEATING SYSTEM (SEALED)		Fit in accordance with BS 7074 Part 1, BS 5449, OFTEC standards and all other relevant legislation.	
Max. Operating Pressure		2 bar	2 bar
Max. System Pressure Cold		1.5 bar	1.5 bar
Min. System Pressure Cold		0.5 bar	0.5 bar
Preset Pressure Relief Valve		3 bar	3 bar
WATER SIDE RESISTANCE			
Flow Rate To Give A Nominal Output At 10K Differential		26kW	35kW
Flow Rate Measured		2135 kg/h	2874 kg/h
Waterside Resistance		0.18 mbar	0.18 mbar
Flow Rate To Give A Nominal Output At 20K Differential		26kW	35kW
Flow Rate Measured		1131 kg/h	1523 kg/h
Waterside Resistance		0.19 mbar	0.19 mbar

5 5.1 SYSTEMPAC CONDENSING BOILER - END USER INFORMATION



To start the boiler:

- Turn on fuel supply.
- Switch on power supply to boiler.
- Turn timer control (if fitted) to "ON".
- Set the boiler thermostat to the required temperature. The boiler thermostat controls the boiler operation by automatically maintaining the required boiler water temperature output. Safe operation is also maintained by the burner control system which provides the required ignition and shut off sequence. If the optional timer control is fitted, this will automatically switch the boiler off and on when heat is required.

To turn off the boiler:

- Turn the timer control (if fitted) to "OFF".
- Turn off the mains electrical supply to the boiler.



BOILER THERMOSTAT/THERMISTOR FUNCTION

The control thermostat on the boiler allows the householder to vary temperature to central heating from a low of 60°C to 80°C, depending on the model.

This boiler is also fitted with a safety high limit thermostat, fixed at 110°C. This system protects the boiler in the event of the control thermostat failing and keeps the boiler safe.

The safety high limit thermostat will shut the boiler off and will require the limit button to be pushed to restart the boiler. It is recommended to call a service engineer to establish the cause.

BURNER LOCKOUT

The boiler is factory fitted with a burner control box lockout safety feature which operates automatically if a fault occurs in the burner operation. Should this occur, the light on the front of the burner will illuminate.

Press the reset button a maximum of two times. If the boiler fails to light, call a service engineer who should check the following:

- A. An interruption in the fuel supply (eg. empty fuel supply tank).
- B. An electrical supply fault.
- C. A fault with the burner or its safety control system.
- D. The failure of a burner component.
- E. Worn or dirty fuel nozzle.
- F. Incorrect flue installation.

To restart the boiler:

1. Press reset button.
2. Ensure that the boiler thermostat, time switch (if fitted) and any external controls connected to the boiler are set to call for heat.
3. Check that the oil supply valves are open and that there is sufficient oil in the tank.
4. Check that the main power supply is on. The boiler is now ready.

5 5.2 SYSTEMPAC CONDENSING BOILER - INSTALLER GUIDELINES

Please note the following important points before commencing installation.

Installation should only be carried out by a competent, qualified engineer, preferably OFTEC registered, familiar with the installation of the Firebird boilers referred to in this manual.

WARNING

The manufacturer cannot accept responsibility for any damage to persons, animals or property due to error in installation or in the burner adjustment or due to improper or unreasonable use or non-observance of the technical instruction enclosed with the burner, or due to the intervention of unqualified personnel.

POSITIONING THE BOILER

In order to comply with the terms and conditions of warranty, when installing a boiler on a new or existing system, the system should be cleaned, flushed and then protected with a suitable protection inhibitor.

Ensure that adequate clearance is available for making the water and flue connections.

The boiler is serviced from the front and a clearance of 750mm must be available at the front of the boiler.

No special hearth is required as the boiler is fully insulated, but the floor must be level and capable of supporting the weight of the boiler and its water content.

Sound levels must also be a consideration. Whilst Firebird condensing liquid fuel boilers are one of the quietest boilers on the market, some householders are particularly sensitive.

A suitable corrosion inhibitor must be added to the heating system.

UNDERFLOOR HEATING

The boiler should not be directly connected to underfloor heating, as a minimum return temperature of 40°C is required (it can be used with underfloor heating with adequate temperature controls to ensure return values are as stated above).

PLASTIC PIPING

The boiler thermostat control and safety system is not designed, and must not be relied on, to protect plastic pipe from overheating. Additional measures must be incorporated into the system pipework for protection in these circumstances. Plastic pipe must never be connected directly to the boiler and there must be at least 1 meter of copper pipe between the boiler and the first plastic connection. If you choose to use plastic pipe anywhere on your heating circuits, please consult the plastic pipe manufacturer for their instruction on how to ensure their product never overheats. Our boiler control and safety high limit thermostats are not designed to fulfil this function.

Firebird accepts no responsibility for failure of plastic piping and fittings for whatever reason.

PRESSURISED HEATING SYSTEM

Normal cold pressure should be set at 1 bar. The maximum operating working pressure is 2 bar when the system is at full operating temperature.

EXPANSION VESSEL

Total water content of system and boiler must be calculated to determine if an additional pressure vessel is required.

MAGNETIC FILTRATION

It is recommended at the time of installation of this boiler, to install a permanent effective magnetic filter on the return pipework after the last radiator on the central heating system. This will maintain maximum operational efficiency and protect the boiler from the damaging, long-term effects of "magnetite" (black iron sludge). It is essential that the filter is sized similar to the return pipework. The magnetic filter must be installed in accordance with the manufacturer's instructions and serviced annually.

HARD WATER - LIMESCALE

On initial fill, where it is suspected that there is a high concentration of scale products, a suitable inhibitor must be used to protect the boiler and system. Check with local water authorities if in doubt (max. 200 ppm).

BURNER

The burners is factory set for use with Diesel 35 Second Gas Oil.

5 5.2 SYSTEMPAC CONDENSING BOILER - INSTALLER GUIDELINES

PIPEWORK

Do not obstruct flue fitting with Pipework.
Connect pipework as shown below.

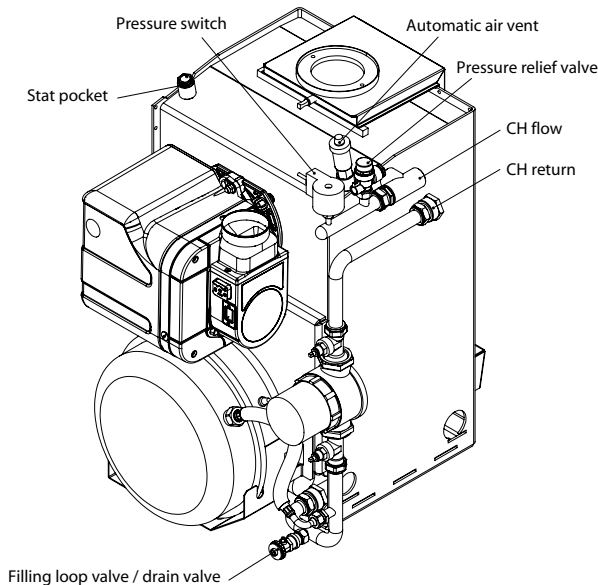

SEALED HEATING CIRCUIT

The system must comply with BS 7074 Part 1 and BS 5449 Part 1 with a maximum water temperature of 80°C.

- * A manual reset overheating limit thermostat is located at the rear of the electrical control panel. If a boiler overheating condition arises the burner will stop and remain inoperative until this thermostat reset button is pressed.

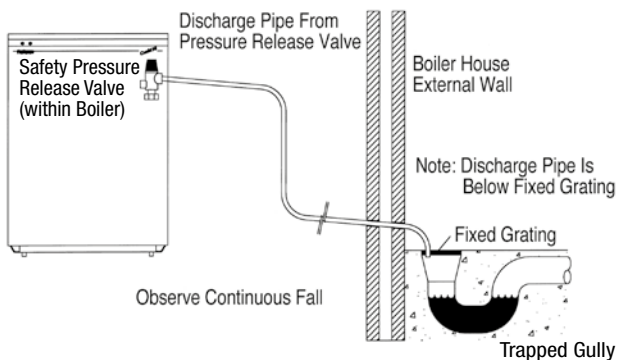

- * A pressure release valve to BS 6759 operating at 3 bar is fitted. A discharge pipe of 15mm diameter is also fitted to the discharge connection on the pressure release valve. During installation an extension pipe should be fitted to this, leading to outside the building. The pipe should be as short as possible and may need a tundish fitted in a protected position within the building.

Note: Water must not discharge above an entrance, window or where public have access. The installer must be aware that the discharge may be boiling water.

- * A pressure gauge with a 0 to 4 bar range is fitted to the boiler control panel. This indicates water pressure in the boiler and system at time of reading. **Pressure when cold should** be 1/2 bar minimum to 1.5 bar maximum. This is known as Initial System Design Pressure (P_i).

N.B. Initial System Design Pressure (measured in bar) equals static head of system (measured in bar) plus 0.3. SEALED HEATING CIRCUIT

The system must comply with BS 7074 Part 1 and BS 5449 Part 1 with a maximum water temperature of 80°C.

- * A manual reset overheating limit thermostat is located at the rear of the electrical control panel. If a boiler overheating condition arises the burner will stop and remain inoperative until this thermostat reset button is pressed.



When the system is cold and filled to initial fill pressure P_i the pointer on the pressure gauge should point to **1 bar**. The pressure gauge shown has **two red zones** marked on it. The first is between 0 and 1/2 a bar. If the pointer falls into this zone when the system and boiler are cold, this indicates that the initial System Fill Pressure has dropped and this will activate the pressure switch cutting off power supply to the boiler. Refill system manually until indicated pressure rises to 1 bar.

N.B. Insufficient pressure in the boiler will cause the power supply to switch off.

- * A 12 litre expansion vessel is fitted to the boiler, precharged with air or nitrogen to **1 bar** which allows a system static head of 5 metres. If the static head is greater than this then the air charge in the vessel must be increased to balance the higher static head. **The air charge should not exceed a pressure of 1.5 bar.**

If the static head is altered, then it is also necessary to alter the air charge pressure to equal the static head (+ 0.3 bar). This is necessary in order to keep the system water from entering the expansion vessel until the system is being heated and thus allow its maximum acceptance volume (V) to be used **only to accommodate the expansion of system water during boiler operation.**

5 5.2 SYSTEMPAC CONDENSING BOILER - INSTALLER GUIDELINES

Remember that air charge pressure **must** be **equal** in both vessels (attached to the same system). In the above example this is 1 bar. **Air charge pressure** is the air pressure in the expansion vessel **before** the system is filled. It is measured with a tyre gauge attached to a Schrader valve on the vessel.

N.B. The second **red zone** is between 2.5 and 4 bar pressure. When the heating system is up to full working temperature, if the pointer on the pressure gauge should enter this **red zone** showing a final system design pressure of more than **2.5 bar**, it is likely that:

- Total** system water content is greater than that calculated and if an additional expansion vessel has been fitted, it should be replaced with a larger unit
OR if only an integral boiler expansion vessel is used, then an additional expansion vessel is required.
- Static head may be higher than calculated. In this case it is necessary to re-measure the static head and revise expansion vessel air charge pressure.
- Expansion vessel size is incorrect or the air charge pressure is incorrect.

**Refer to BS 7074
Part 1 and BS 5449 for further information.**

EXPANSION VESSEL AND SYSTEM REQUIREMENTS

Safety Valve Setting	3 bar		
Initial System Pressure	0.5 bar	1.0 bar	1.5 bar
Total Water Content of System	Total Vessel Volume **		
Litres	Litres	Litres	Litres
25	2.1	2.7	3.9
50	4.2	5.4	7.8
75	6.3	8.2	11.7
100	8.3	10.9	15.6
125	10.4	13.6	19.5
150	12.5	16.3	23.4
175	14.7	19.1	27.2
200	16.7	21.8	31.2
225	18.7	24.5	35.1
250	20.8	27.2	39.0
FOR FURTHER INFORMATION, CONSULT APPROPRIATE TRAINING MANUALS, BS 7074-1: 1989, BS EN 12828: 2012 + A1: 2014 AND ANY OTHER RELEVANT STANDARDS & REGULATIONS.			
* * When calculating the size of any additional expansion vessel, remember to deduct the boiler expansion vessel volume of 12 litres from the calculated total system vessel volume required, as given in the above table.			

EXAMPLE: using above table

If total water content of system is	- 150 litres
and initial system pressure required is	- 1.0 bar
then vessel volume required is	- 16.3 litres
<small>[from above table]</small>	
The vessel supplied with boiler is	- 12.0 litres
therefore an additional vessel of is required	- 4.3 litres
	<small>(minimum)</small>

(For this system of 150 litres - total water volume)

The nearest available stock size for the additional vessel required at 1 bar initial system pressure (taken from table), is 5 litres.

It is emphasised that the installer should be fully acquainted with sealed system installation and operation, calculation of total system water volume, determining of initial system pressure required and calculation of any additional expansion vessel volume required. **The warranty is void if the boiler is installed in a system with insufficient expansion.**

NB. Ensure that all expansion vessels in the same system are set at EQUAL air charge pressures.

SYSTEM FILLING, TESTING AND MAKE-UP

Introduction

Mains cold water is supplied through the boiler drain/fill valve.

Heating Circuit

This is the heating system including the boiler which is filled from the mains supply via a flex filling loop to a pressure determined from the system static head, expansion vessel size and system water volume. This flexible filling loop should be disconnected when boiler and system are filled and checked.

NOTE: There shall be no direct connection to the mains, even with the use of a non-return valve without the permission of Local Water Authority.

* It is recommended that an inhibitor be added at the time of final fill to protect the System from corrosion. Ensure that this is carried out in accordance with inhibitor manufacturers instructions. Installer should ensure that inhibitor used is suitable and that it will have no adverse effect on Expansion Vessels diaphragms or any other part or component of the system.

5 5.2 SYSTEMPAC CONDENSING BOILER - INSTALLER GUIDELINES

WIRING

Electrical Supply

The boiler and controls require a 230V 50Hz mains electric supply protected with a 5A fuse.

This appliance must be earthed.

A qualified electrician must carry out all electric wiring in accordance with current ETCI / IET Regulations and any local regulations which may apply.

The boiler must have a permanent power supply to enable overrun and frost protection. The hot water and central heating should be timed separately.

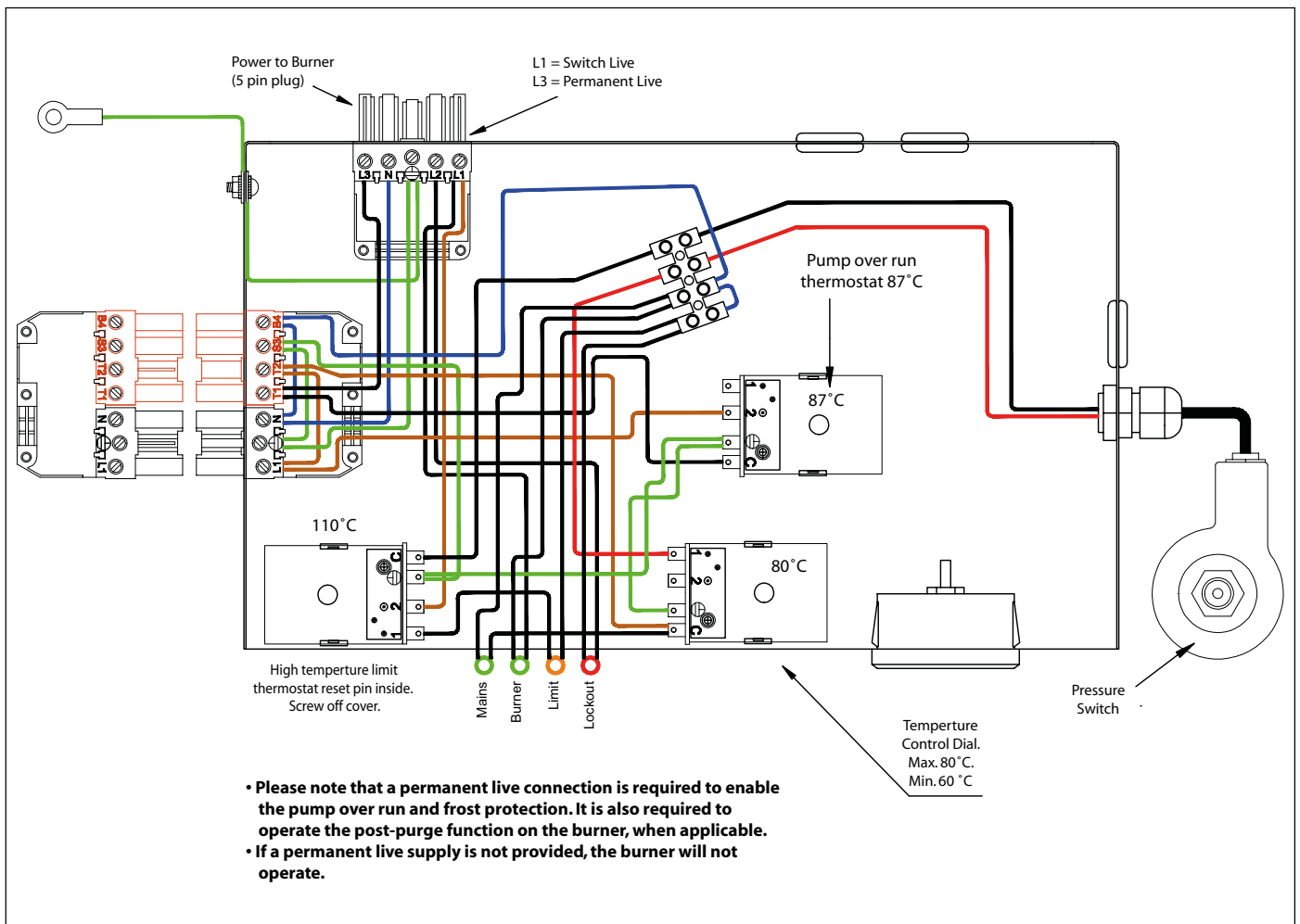

5 5.3 SYSTEMPAC CONDENSING BOILER - TECHNICAL DETAILS

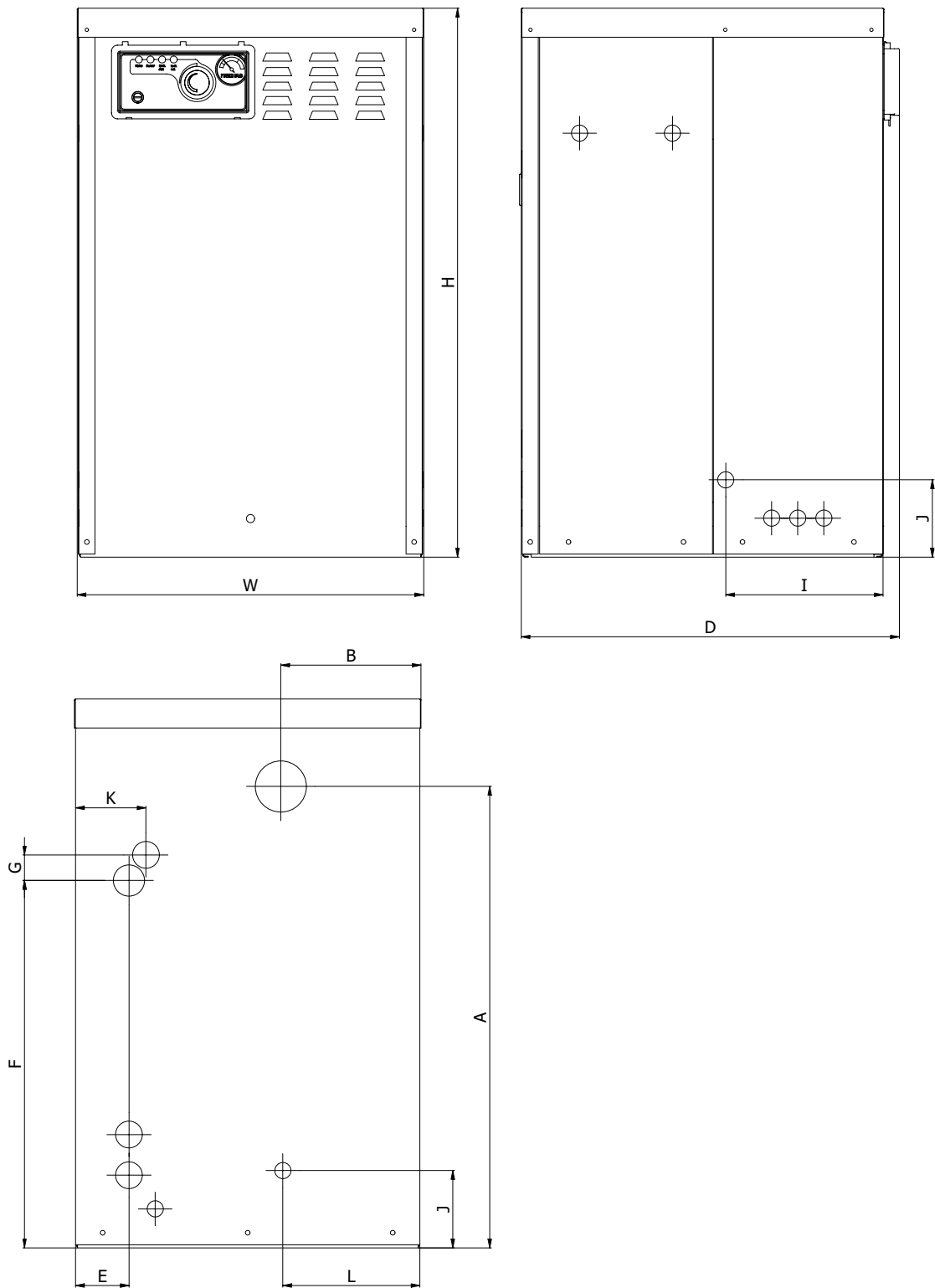

Model - Systempac Condensing (output range)	Weight kg	Dimensions (mm)											
		H	W	D	A	B	E	F	G	I	J	K	L
C26 Systempac Condensing 26kW	160	945	597	651	795	242	92	633	44	271	133	121	236
C35 Systempac Condensing 35kW	163	945	597	651	795	242	92	633	44	271	133	121	236

5 5.3 SYSTEMPAC CONDENSING BOILER - TECHNICAL DETAILS

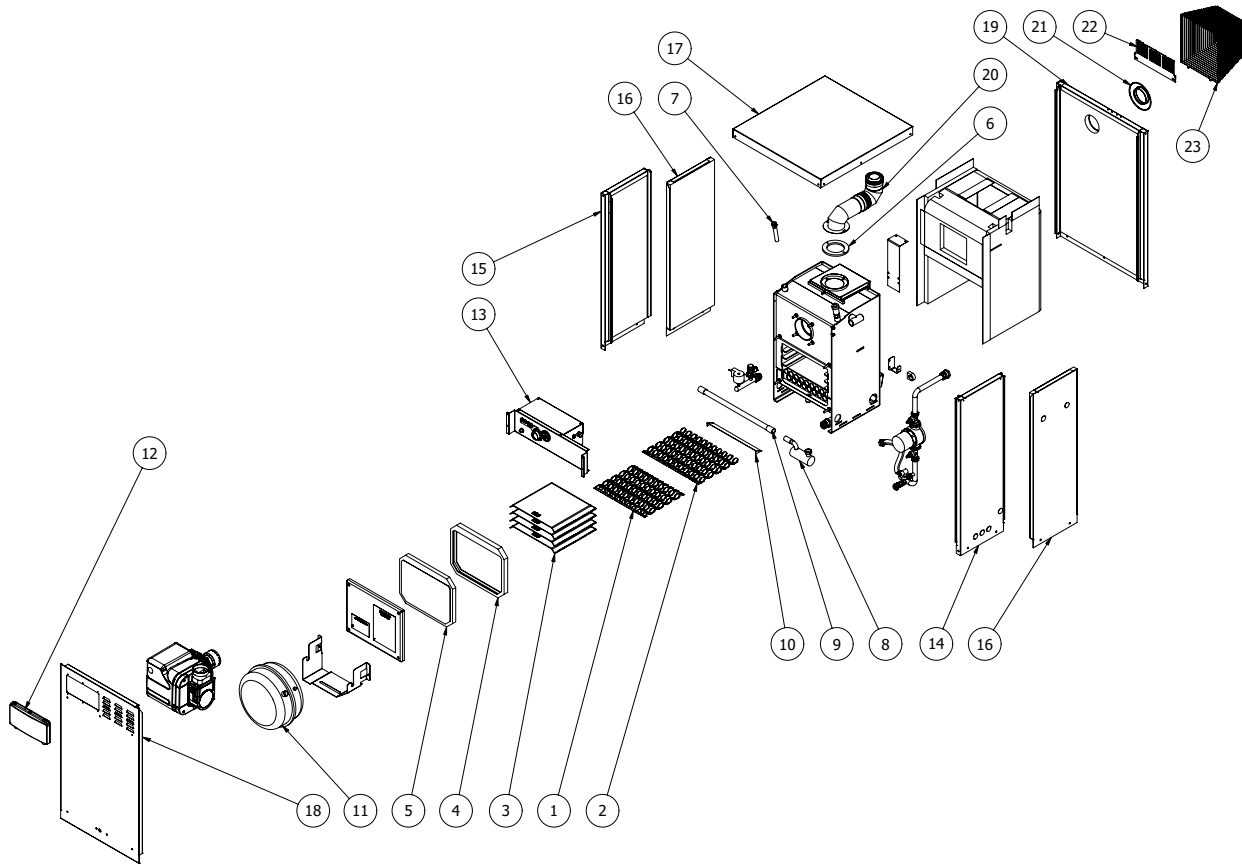

No.	Qty	Description	26 kW	35 kW
1	4	Tube baffle	BA110907	BA110907
2	5	Tube baffle single	BA110908	BA110908
3	4	Smoke baffle	BA212028/BA212122	BA212028/BA212122
4	1	Door seal	ACC035GRA	ACC035GRA
5	1	Door duroboard	ACC035GSK	ACC035GSK
6	1	Flue gasket	ACC000FRG	ACC000FRG
7	1	Stat pocket	ACC003PKT	ACC003PKT
8	1	Condensate trap	ACC000TRP	ACC000TRP
9	1	Condensate hose	ACC000FLX	ACC000FLX
10	1	Heat deflector	ACC000HTD	ACC000HTD
11	1	Pressure vessel	ACC012PVL	ACC012PVL
12	1	Inspection window	115027	115027
13	1	Control panel	315039	315039
14	1	Fixed right panel	ACCP002CCP	ACCP002CCP
15	1	Fixed left panel	ACP003CCP	ACP003CCP
16	1	Removable panel	ACP103CCP	ACP103CCP
17	1	Casing top	215034	215034
18	1	Casing front	215031	215031
19	1	Casing back	215035	215035
20	1	Flue kit	HPF035KIT	HPF035KIT
21	1	Flue seal	110721	110721
22	1	Basket plate	214261	214261
23	1	Condense terminal guard	ACC000CTG	ACC000CTG

5 5.3 SYSTEMPAC CONDENSING BOILER - TECHNICAL DETAILS

HEAT OUTPUT	kW	26	35
CONNECTIONS		-	-
Heating Flow		22 mm dia.	28 mm dia.
Heating Return		1" BSP	1" BSP
Mains Cold Feed (Copper)		15 mm dia.	15 mm dia.
Drain Off Valve		½" BSP	½" BSP
Safety Pressure Valve Outlet (Copper)		15 mm dia.	15 mm dia.
Condensate Trap		22 mm dia. plastic pipe	22 mm dia. plastic pipe
CIRCULATING PUMP		25/60	25/60
Integral Expansion Vessel Normal Capacity		12 litres	12 litres
Expansion Vessel Pre-charge Pressure		1 bar	1 bar
Low Pressure Water Switch?		✓	✓
Filling Loop Included?		✓	✓
WATER CONTENT		-	-
Boiler		24 litres	24 litres
FLUE (INDOOR BOILERS)		-	-
Balanced Flue Assembly		125 (5") mm dia.	125 (5") mm dia.
Max. Low Level Flue Length		1.5m	1.5m
Max. High Level Balanced Flue Length		6m	6m
HEATING SYSTEM (SEALED)		Fit in accordance with BS 7074 Part 1, BS 5449, OFTEC standards and all other relevant legislation.	
Max. Operating Pressure		2 bar	2 bar
Max. System Pressure Cold		1.5 bar	1.5 bar
Min. System Pressure Cold		0.5 bar	0.5 bar
Preset Pressure Relief Valve		3 bar	3 bar
WATER SIDE RESISTANCE			
Flow Rate To Give A Nominal Output At 10K Differential		26kW	35kW
Flow Rate Measured		2135 kg/h	2874 kg/h
Waterside Resistance		0.18 mbar	0.18 mbar
Flow Rate To Give A Nominal Output At 20K Differential		26kW	35kW
Flow Rate Measured		1131 kg/h	1523 kg/h
Waterside Resistance		0.19 mbar	0.19 mbar

COMMISSIONING

- ◆ It is the responsibility of the installer/end user to ensure that the boiler is properly commissioned when first used.
- ◆ The boiler should be commissioned by a competent, qualified engineer, preferably familiar with Firebird products.
- ◆ The commissioning card should be completed and posted to Central Heating New Zealand within 28 days of installation and a copy should be retained by the commissioning engineer.
- ◆ The system should be checked thoroughly.

PROCEDURES

DIESEL TANK

The installation of the Diesel tank and supply line should comply with all the instructions shown earlier in this manual. Consult OFTEC Book 3.

If a single supply line is used, ensure that the bottom of the tank is above the burner. A suction line system via a deaerator should be used where the level of the diesel in the tank may fall below the level of the oil burner pump.

Check and ensure correct grade fuel oil has been supplied.

CHECKLIST FOR INSTALLING AND COMMISSIONING A FIREBIRD BOILER

Pre-installation check:

- ◆ Is the following documentation included with the boiler, installation manual, burner book?
- ◆ Is the base on which the boiler is to be installed solid?
- ◆ Allow sufficient room for future servicing of the boiler.

Where does the flue terminate:

- ◆ Make sure there is no window, door or fence within 1 metre of the flue-terminal.
- ◆ If the flue terminates in a corner or into an allyway, re-circulation of the combustion gases in the air intake could occur. A plume dispersal may be required or an alternative flue arrangement might be available. Contact the Central Heating New Zealand technical department.
- ◆ The appropriate class 1 flue must be used with a conventional flue installation. Contact Central Heating New Zealand if unsure.

Power supply:

- ◆ Is a timed and permanent power supply available, via a fused spur with a 5amp fuse.

Oil supply:

- ◆ The burner is set for Diesel 35 Second Gas Oil
- ◆ Check that there is a good quality filter on the line with an isolating valve.
- ◆ There should be a remote sensing fire valve.
- ◆ If a deaerator is required, fit the bypass screw in the diesel pump. Check that the second flexible diesel line is approved by the manufacturer.
- ◆ Verify that the diesel tank has been installed correctly as per building standards.

Boiler check:

- ◆ Baffles should be checked as they many have been disturbed during transport.
- ◆ Check that the condensate trap is fitted securely, primed with water and piped out into a suitable drain. It is easier to check the trap when the boiler door is removed.
- ◆ The boiler door should be refitted, complete with graphite seal and then tightened.

Flue check:

- ◆ The flue must be fitted correctly, with a fall back to the boiler. Note: internal fall of 2.5° within the flue.
- ◆ For concentric balanced flue:
 - the cone supplied should be inserted in to the end of the flue;
 - the wall plate should be fitted with an opening for air under the flue;
 - check that the flue guard is fitted.
- ◆ When installing a Systempac, the 90° bend should be fitted pointing up.

Burner set-up:

- ◆ Check that the nozzle is the right size for the type of boiler and for the system heat demand.
- ◆ Set the air to what is required for the nozzle size +.5 on the dial - example: the factory setting for a Firebird C26 has a Danfoss 0.6 80° ES nozzle with a pump pressure of 10.5 bar. Please refer to the burner manual for the air setting.
- ◆ Check all connections for possible leaks.
- ◆ Turn on the oil supply and switch on power to the boiler.
- ◆ Set the thermostat at minimum.
- ◆ Use a smoke gun to check clean combustion.

Flue gas analysis and fine tuning of burner:

- ◆ Ensure flue gas is over 50°C when setting CO₂.
- ◆ Allow the boiler to run for a period of time before fine tuning to the Firebird settings.
- ◆ This fine tuning should be done with the boiler in the condition it is going to be operating at, that is, if a balanced flue is installed, the air hose is fixed on the burner. In the case of a Slimline Heatpac, ensure that the door is closed for a period of time before setting the analyser on the system.

6 COMMISSIONING

Note: When fine tuning the burner with the flue gas analyser, adjustments in both the air and pump pressure may be required to achieve the desired CO₂ %.

- ◆ Print off a copy of the flue analysis and attach to the commissioning card.
- ◆ Make sure the flue gas analysis plug is replaced correctly into the flue when finished the flue analysis.
- ◆ Check the correct operation of the thermostat on the boiler.

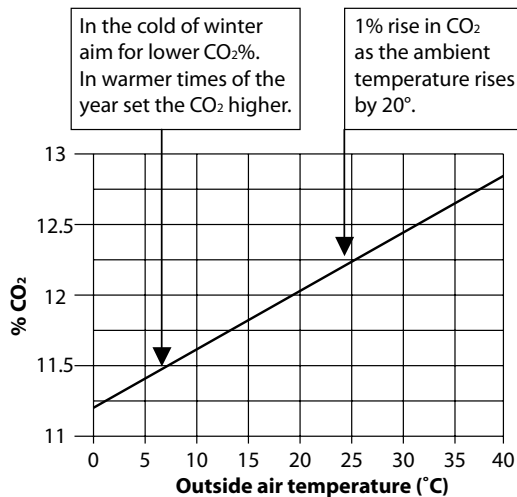

COMMISSIONING

Before proceeding to filling, ensure that electricity supply is switched off at mains to avoid any possibility of time switch operating and passing power to appliance prior to filling.

Filling and Testing

Check that all connections, especially compression joints, are fully tightened. Re-check and ensure that the pressure vessel air charge is correct, then fill the system with water via the filling system used. **Turn off the water supply before system pressure reaches safety valve operation point of 3 bar** (2 to 2.5 bar). Vent system via all manual air vents **including circulating pumps**, boiler, radiators, system high points. etc. Check that dust caps are loosened on auto air vents, keep constant check on system pressure gauge (fitted to control panel). If pressure has dropped re-admit water to above pressure. Ensure all appropriate boiler and system valves are open.

With the water supply turned off, **thoroughly** flush out the boiler and system to remove **all** foreign matter before allowing the boiler and pumps to operate. If in doubt, drain the system and repeat above procedure. At this stage flushing-out water should be clean and clear of all foreign matter.

Refill the system and again vent at all points as described. Examine the complete system for water leaks having pressurised it to 1 - 2.5 bar. Correct any leaks, then check operation of the safety valve by admitting further water until this valve operates. This should occur when system

pressure rises to between 2.7 and 3.3 bar. When satisfied with valve operation, and with mains water still turned off, draw off sufficient water until initial system design fill pressure (P_f). (cold fill) is established (0.5 - 1 bar - as calculated for system).

Remember that initial cold fill pressure can only be checked when system water has properly cooled down. Check that the **final operating pressure** (P_f) is under 2.5 bar with all radiators turned on and up to the highest working temperature. Should system operating pressure exceed this, check:



1. That initial cold fill pressure is correct and , if additional expansion vessel is fitted, that pressure is equal in each vessel.
2. That expansion vessels are sized correctly.

Special attention should be given to existing heating systems where a Firebird boiler has replaced an existing unit. Extra effort should be made to ensure that all original pipe work and radiators are repeatedly flushed. If possible use a proprietary cleansing agent suitable for the system as loosened scale and foreign matter can seriously reduce domestic hot water performance and pump efficiency.

Use corrosion inhibitor of suitable type.

HANDING OVER

The end user should receive:

- A clear and concise demonstration of the boiler operation and any system controls.
- This manual, the burner manufacturer's manual and any other instructions.
- OFTEC forms CD10 and CD11.

The end user should be advised to:

- Service the boiler annually and to ensure that the service records are completed.
- Read the terms and conditions of warranty.
- Keep all boiler documentation in a safe place.

A commissioning record should be completed and a copy retained by the Engineer.

Annual servicing must be carried out by a competent, qualified engineer, preferably familiar with Firebird products.

Do not commence service until both the electrical and diesel supply to the boiler have been safely isolated.

THE DIESEL TANK

Check for diesel leaks. Draw off any accumulated water and sludge from the tank by opening the drain valve. Turn off the diesel supply and remove the filter bowl, then wash the element clean with diesel. Fit a new element if required.

THE BOILER

Remove combustion access door for access to baffles and to clean heat exchanger.

Cleaning a Firebird condensing boiler:

1. Remove all baffles, including the tubular baffles in the condensing section and clean them.
2. Remove the condense trap and clean it, place a tray under the connection for the trap. Vacuum out any loose debris from the chamber.
3. Clean the inside of the boiler with a vacuum cleaner.
4. Refit all the baffles and the condensate trap securely.
5. System pressure should not exceed 2 bar at full operating temperature. The expansion vessel should be checked during the annual service to ensure that it is operating correctly.

Check insulation sealing and the silver foil lining in combustion access door - replace if necessary. Check graphite seal and replace if necessary. When refitting this door be careful not to damage the foil and insulation by over tightening.

Check that the condensate trap is secure in position, clean and free of combustion debris. Ensure that the condensate drain is free and not blocked.

Expansion vessel pre-charge pressure should be checked annually.

THE BURNER

Check Diesel nozzle size and replace (see burner section for details).

Ensure correct specification replacement nozzle is used.

1. Check all diesel filters and replace as necessary.
2. Remove burner and clean blast tube and ensure that airways are clear.
3. Ensure electrodes are clean, dry, not broken and are set as per burner specifications.
4. Clean fan and photocell.
5. **Once again check flexible diesel lines and connections for damage or leaks, replace as necessary. Replace flexible diesel lines every 2 years.**

Combustion Check

1. Carry out a combustion analysis.
2. Follow the steps as set out in the burner set-up section.
3. Check safety operation, pull out the photo cell, cover and make sure the burner locks out.
4. Check the thermostat operation.
5. Allow the boiler to operate for at least two full "on/off" cycles.

Ensure service record is completed.

8 TERMS & CONDITIONS OF WARRANTY

Firebird products are designed and manufactured to give many years of trouble free service.

The terms laid down in the warranty must be adhered to.

- ◆ Firebird provides a comprehensive, conditional warranty of 5 years on the boiler shell and 2 years on all other parts from date of installation, provided installation has occurred within 12 months from date of purchase.
- ◆ The 5 year boiler shell warranty consists of parts and labour for the first 3 years and parts only for years 4 and 5.
- ◆ The warranty will only apply if the boiler is commissioned by an OFTEC registered or competent, qualified engineer and is serviced annually thereafter.
- ◆ Please ensure that the commissioning card is fully completed by a competent, qualified engineer and is returned to Central Heating New Zealand within 28 days of complete installation and commissioning.
- ◆ Correct commissioning will ensure that your boiler is set to operate at its maximum fuel efficiency.
- ◆ Consumable components, the nozzles and the oil hose are excluded.

TERMS & CONDITIONS OF WARRANTY

1. Warranty implies that the product shall be free from defective parts or workmanship for a period of warranty cover, which begins from the date of installation.
2. All claims under the warranty programme must be within the time limits stated on the left.
3. Installation and commissioning of the product must be in accordance with (a) instruction/technical manuals (b) all relevant standards and codes of practice.
4. A competent, qualified engineer, using the correct installation and test equipment must carry out installation and commissioning.
5. This warranty does not cover special, incidental or consequential damages, injury to persons or property, or any other consequential loss.
6. Servicing of the boilers is to be carried out annually to maintain the manufacturer's warranty.
7. Firebird accepts no liability in respect of any defect arising from incorrect installation, negligence, fair wear and tear, misuse, alteration or repair by unqualified persons.
8. Firebird will not accept any liability in respect of any defect occurring to the product due to limescale build-up and or low return water temperature.
9. The warranty programme extends to reasonable labour costs EXCEPT in the case of a 5 year warranty period whereby any valid claim made after 3 years will not include labour costs.
10. Firebird's prior authorisation must be obtained before examination or repair of the product takes place.
11. Firebird will examine all claims made under the warranty programme and for any claims that are deemed invalid, the costs incurred will be borne by the owner.
12. The warranty programme only applies where the product was used for normal domestic heating purposes.
13. Any defective part removed under any or all of the warranty programmes MUST be returned to Central Heating New Zealand.
14. Burner controls and flue kits (supplied by Firebird), will be free from defective parts or workmanship for a period of 2 years from the date of installation (with the exception of burner nozzles, which must be replaced at the recommended service intervals).

*STATUTORY RIGHTS OF THE OWNER ARE NOT
AFFECTED BY THIS WARRANTY*

Service Record

NB: All Information recorded hereunder should also be included in the Engineer's own filed service reports. It is recommended that the boiler be serviced **at least once a year** and the details recorded below. The Engineer should advise the end user.

	1 ST SERVICE	2 ND SERVICE	3 RD SERVICE	4 TH SERVICE	5 TH SERVICE
Burner Model <input type="checkbox"/>
Diesel Type <input type="checkbox"/>
Nozzle Type <input type="checkbox"/>
Nozzle Size <input type="checkbox"/>
Nozzle Angle <input type="checkbox"/>
Pump Pressure <input type="checkbox"/>
Air Setting <input type="checkbox"/>
Smoke Reading <input type="checkbox"/>
CO.% <input type="checkbox"/>
F.G.T. °C <input type="checkbox"/>
Fire Valve Location <input type="checkbox"/>
Condensate Trap (where fitted)					
Condensate Trap Piped to Drain <input type="checkbox"/>
Condensate Trap Primed <input type="checkbox"/>
Float and Condensate Trap in Place <input type="checkbox"/>
CHECK					
Flue Seals <input type="checkbox"/>
Deflector Plate and Baffles <input type="checkbox"/>
Graphite Door Seal and Gasket <input type="checkbox"/>
CHECK					
All Connections <input type="checkbox"/>
Central Heating Operation <input type="checkbox"/>
Boiler Thermostat Operation <input type="checkbox"/>
Date:
Service Engineer:
Tel. No:
Signature:
Comments:



For further information on Firebird products please contact:

Central Heating New Zealand Ltd.,

52 Pilkington Way,

Wigram,

Christchurch 8042,

New Zealand.

Tel: + (0) 64 3357 1233

www.centralheating.co.nz

© Copyright applies to all FIREBIRD products. Our policy is one of continual development and we therefore reserve the right to change without prior notice the specification of our products at any time and be without obligation to make similar changes in products previously produced.

MLOBNZE000