

Note 1:
Inside all tapping:
-No burr
-No paint

Note 2:
No burr and any sharp edge on part surface.
Refer to DIN 2768/M for unspecified tolerances.
No any deformation on visible surface after bending.

Note 3:
For 1703 mm product: 0,00805 kg of paste will be used.
For 1420 mm product: 0,00644 kg of paste will be used.
For 1230 mm product: 0,00575 kg of paste will be used.
For 1110 mm product: 0,00506 kg of paste will be used.
For 803 mm product: 0,00391 kg of paste will be used.
For 690 mm product: 0,00322 kg of paste will be used.

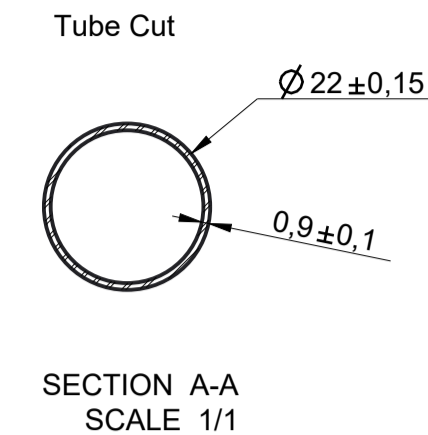
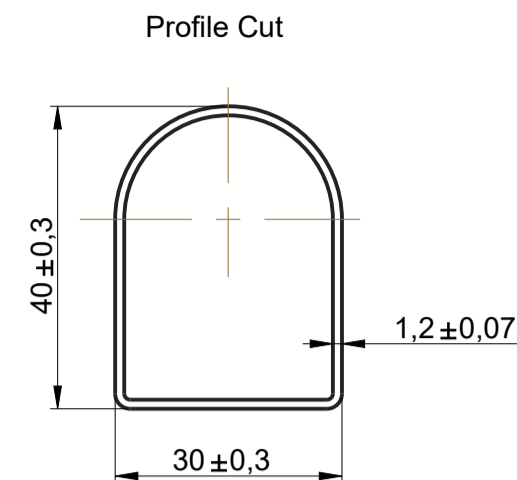
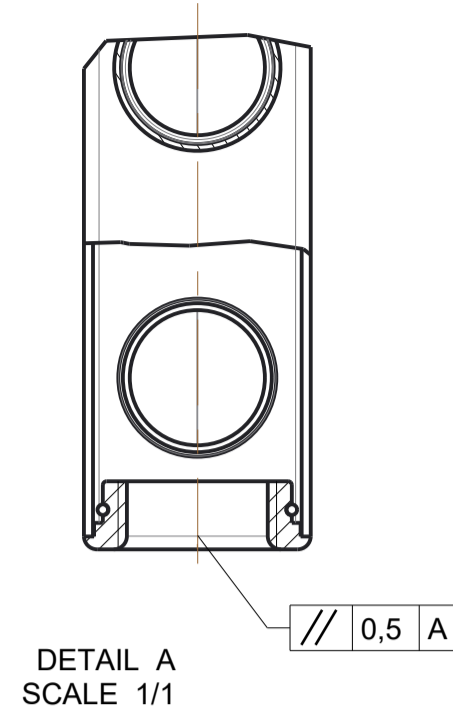

SECTION A-A
SCALE 1/1

MODEL	L	I	Surface Roughness
SANREMO Straight Frame 690x400	400	350	For Chrome Coating Maximum Surface Roughness: 0.4 µm For Paint Maximum Surface Roughness: 1.2 µm
SANREMO Straight Frame 690x450	450	400	
SANREMO Straight Frame 690x500	500	450	
SANREMO Straight Frame 690x550	550	500	
SANREMO Straight Frame 690x600	600	550	
SANREMO Straight Frame 690x750	750	700	
SANREMO Straight Frame 803x450	450	400	
SANREMO Straight Frame 803x500	500	450	
SANREMO Straight Frame 803x550	550	500	
SANREMO Straight Frame 803x600	600	550	
SANREMO Straight Frame 803x750	750	700	
SANREMO Straight Frame 1110x400	400	350	
SANREMO Straight Frame 1110x450	450	400	
SANREMO Straight Frame 1110x500	500	450	
SANREMO Straight Frame 1110x550	550	500	
SANREMO Straight Frame 1110x600	600	550	
SANREMO Straight Frame 1110x750	750	700	
SANREMO Straight Frame 1230x400	400	350	
SANREMO Straight Frame 1230x450	450	400	
SANREMO Straight Frame 1230x500	500	450	
SANREMO Straight Frame 1230x550	550	500	
SANREMO Straight Frame 1230x600	600	550	
SANREMO Straight Frame 1230x750	750	700	
SANREMO Straight Frame 1420x450	450	400	
SANREMO Straight Frame 1420x500	500	450	
SANREMO Straight Frame 1420x550	550	500	
SANREMO Straight Frame 1420x600	600	550	
SANREMO Straight Frame 1420x750	750	700	
SANREMO Straight Frame 1703x400	400	350	
SANREMO Straight Frame 1703x450	450	400	
SANREMO Straight Frame 1703x500	500	450	
SANREMO Straight Frame 1703x550	550	500	
SANREMO Straight Frame 1703x600	600	550	
SANREMO Straight Frame 1703x750	750	700	

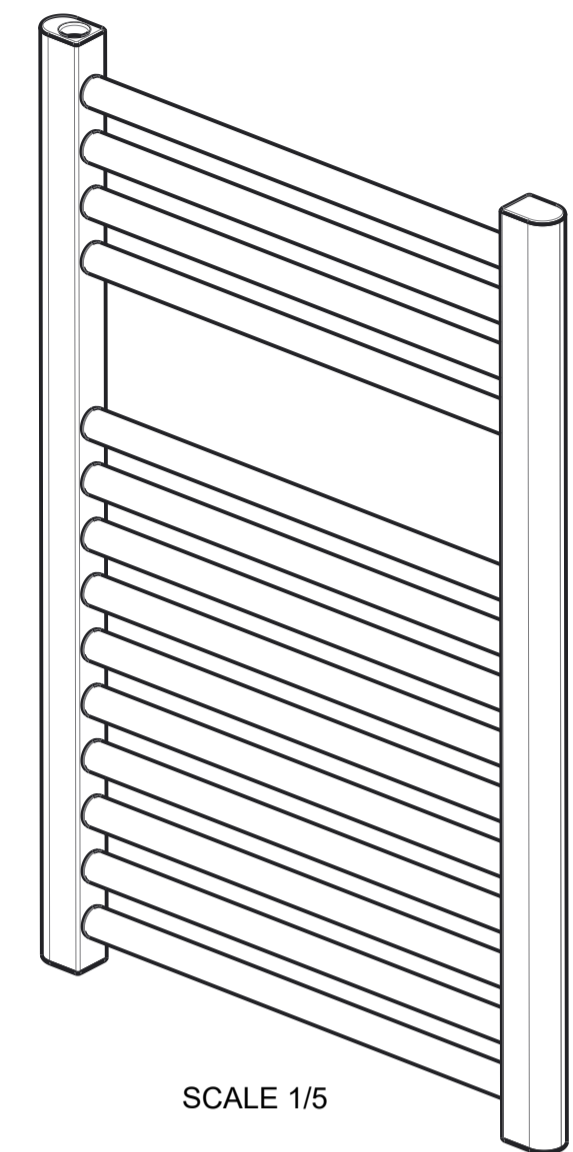

SCALE 1/5

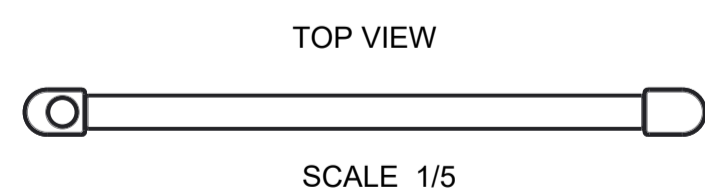
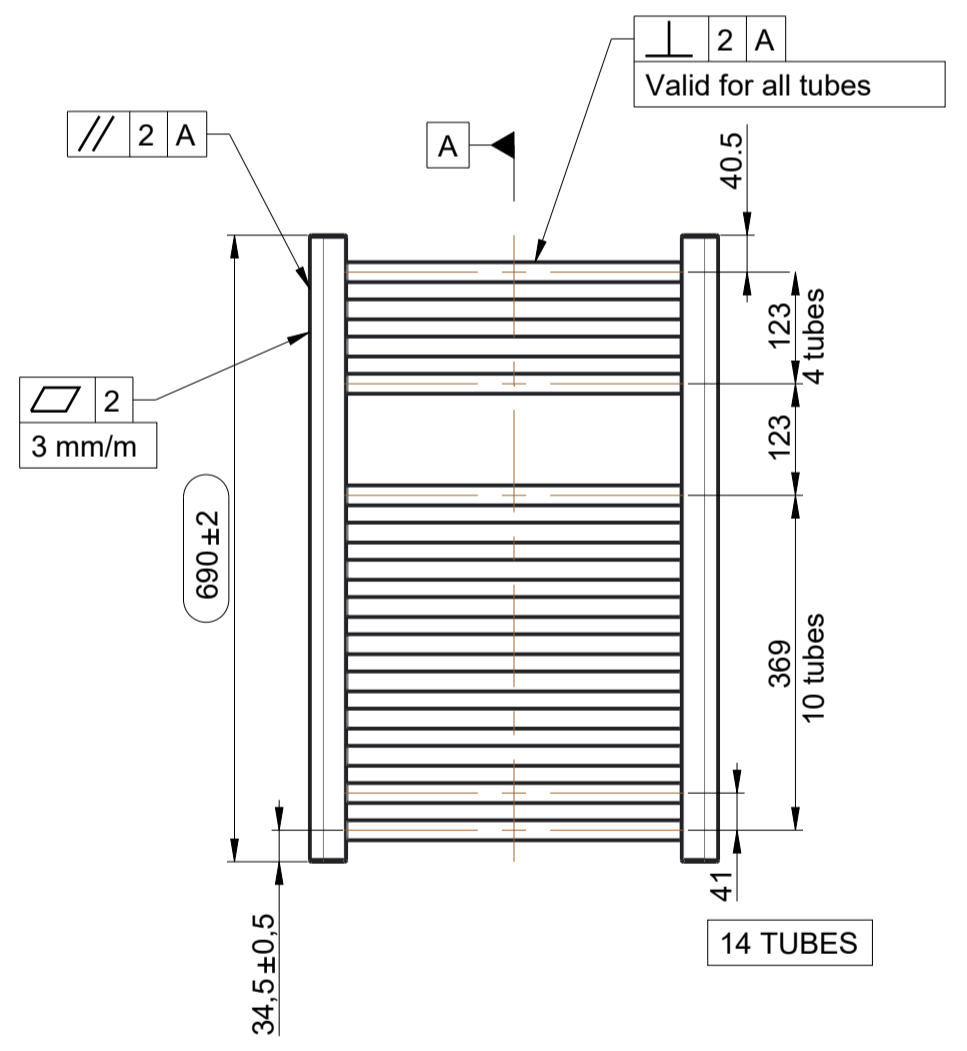
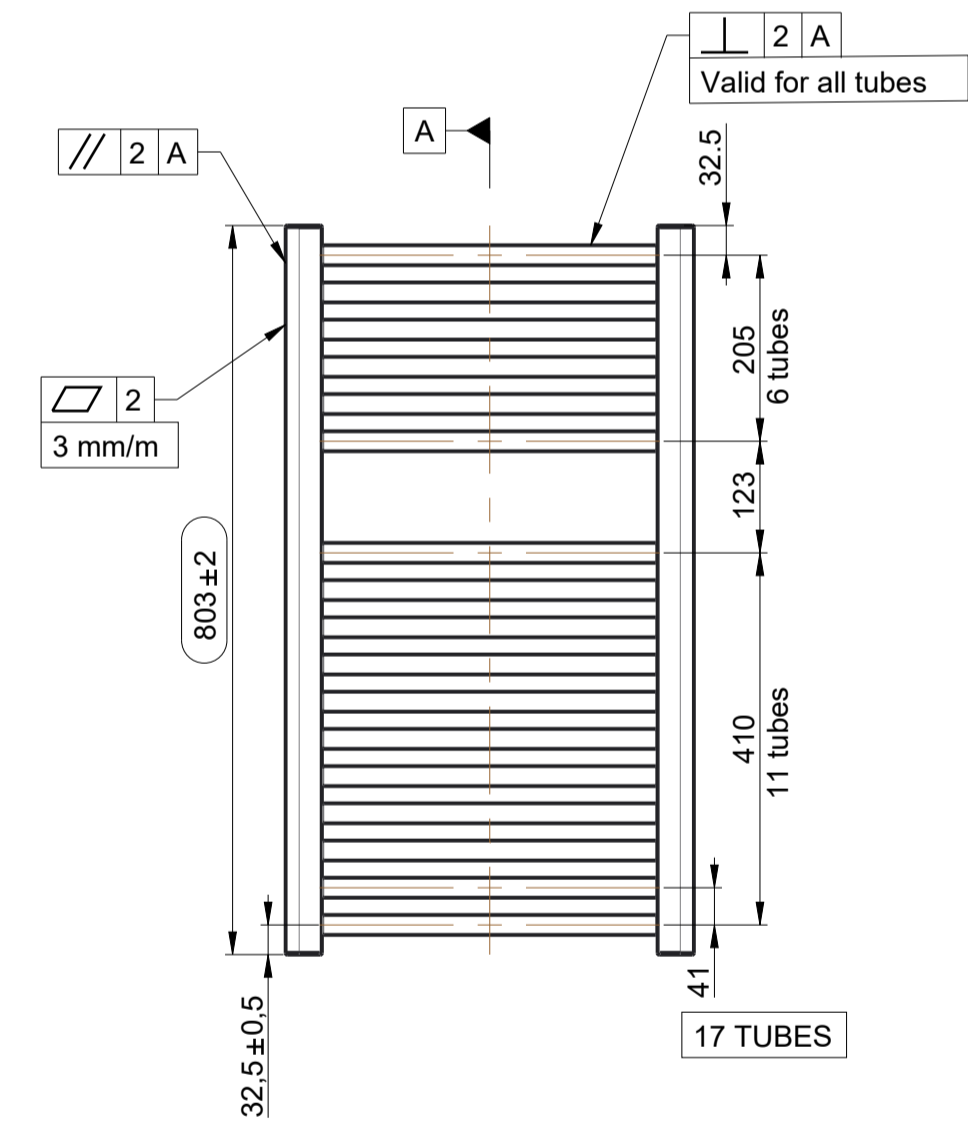
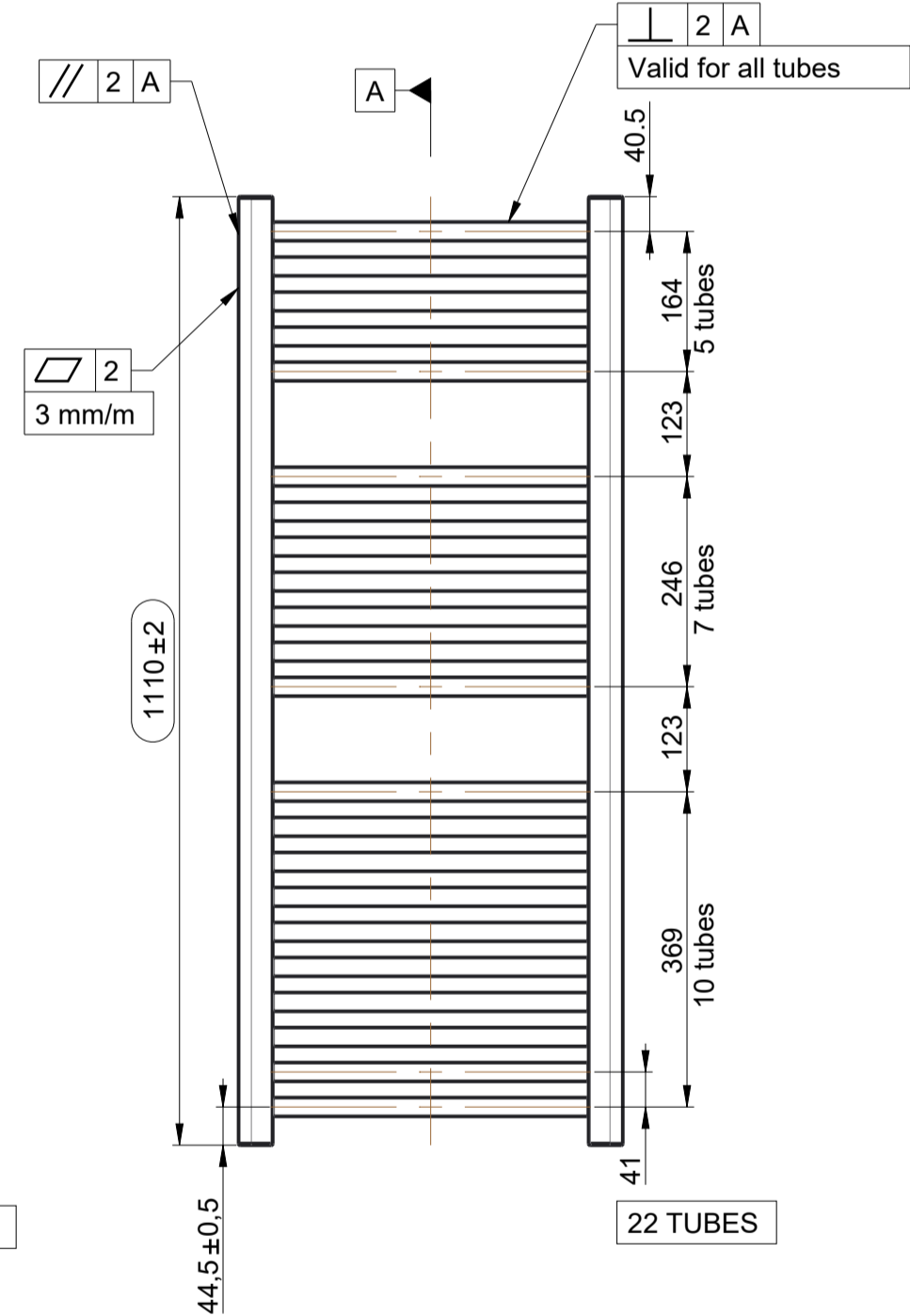
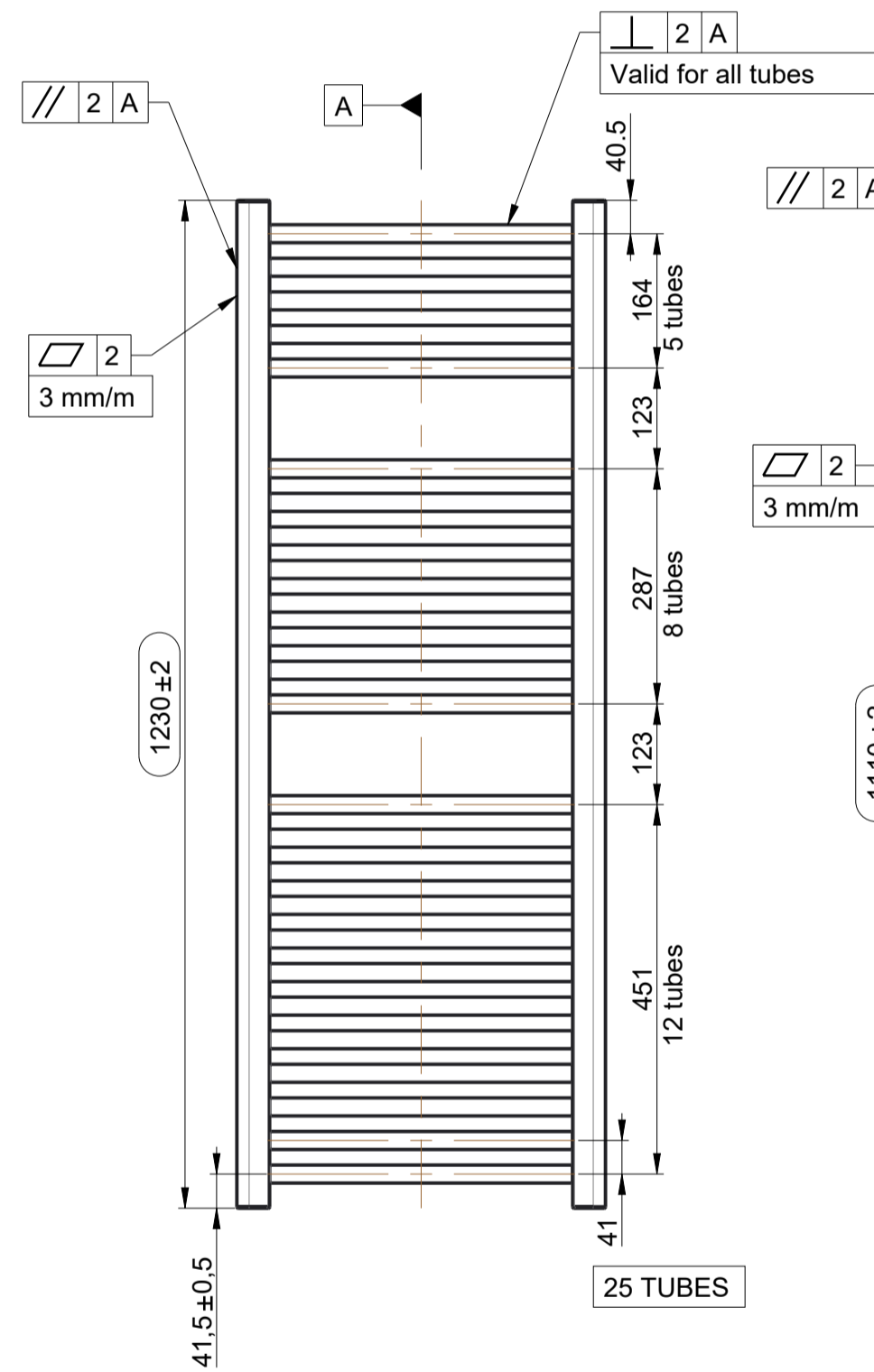
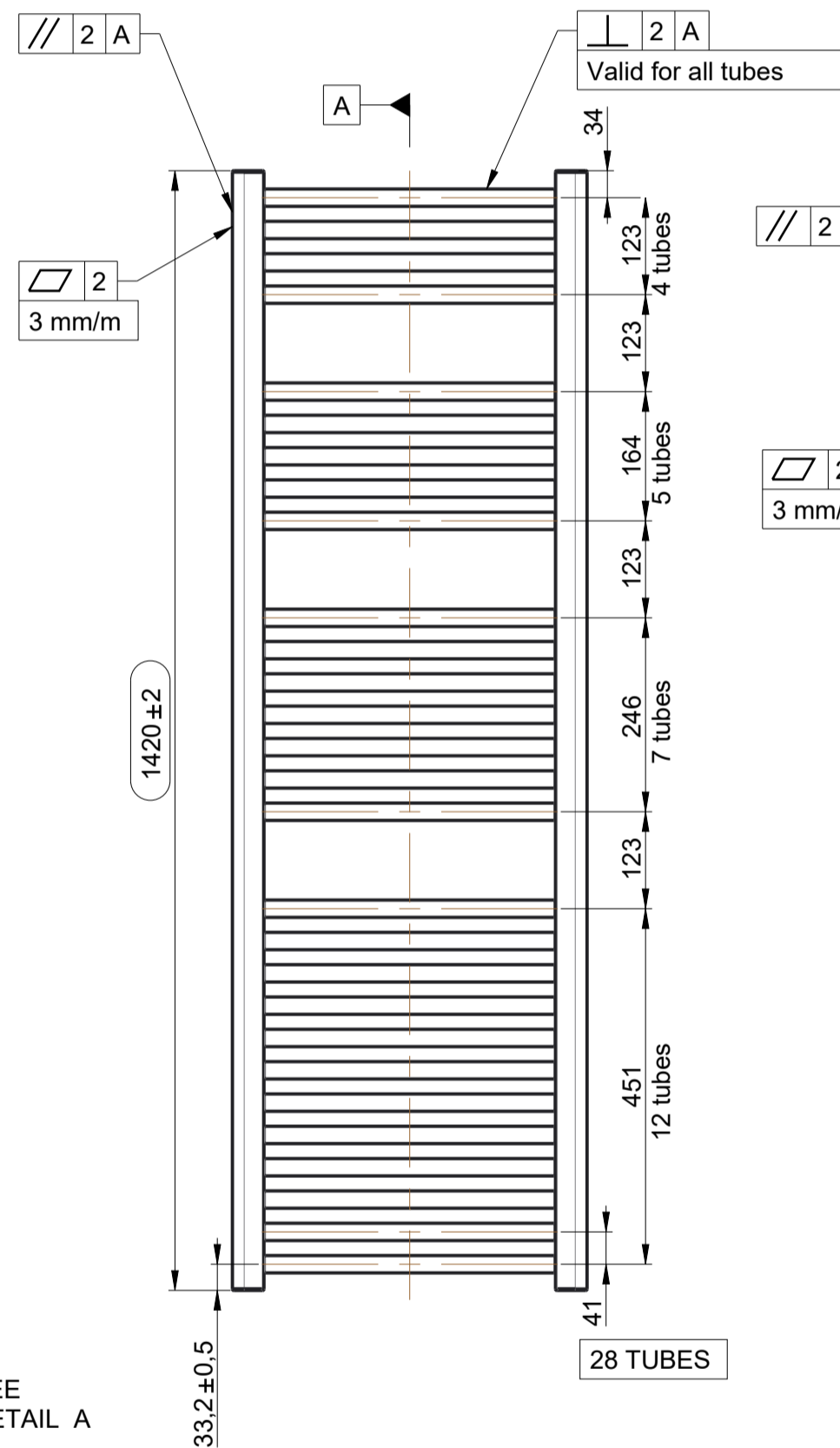
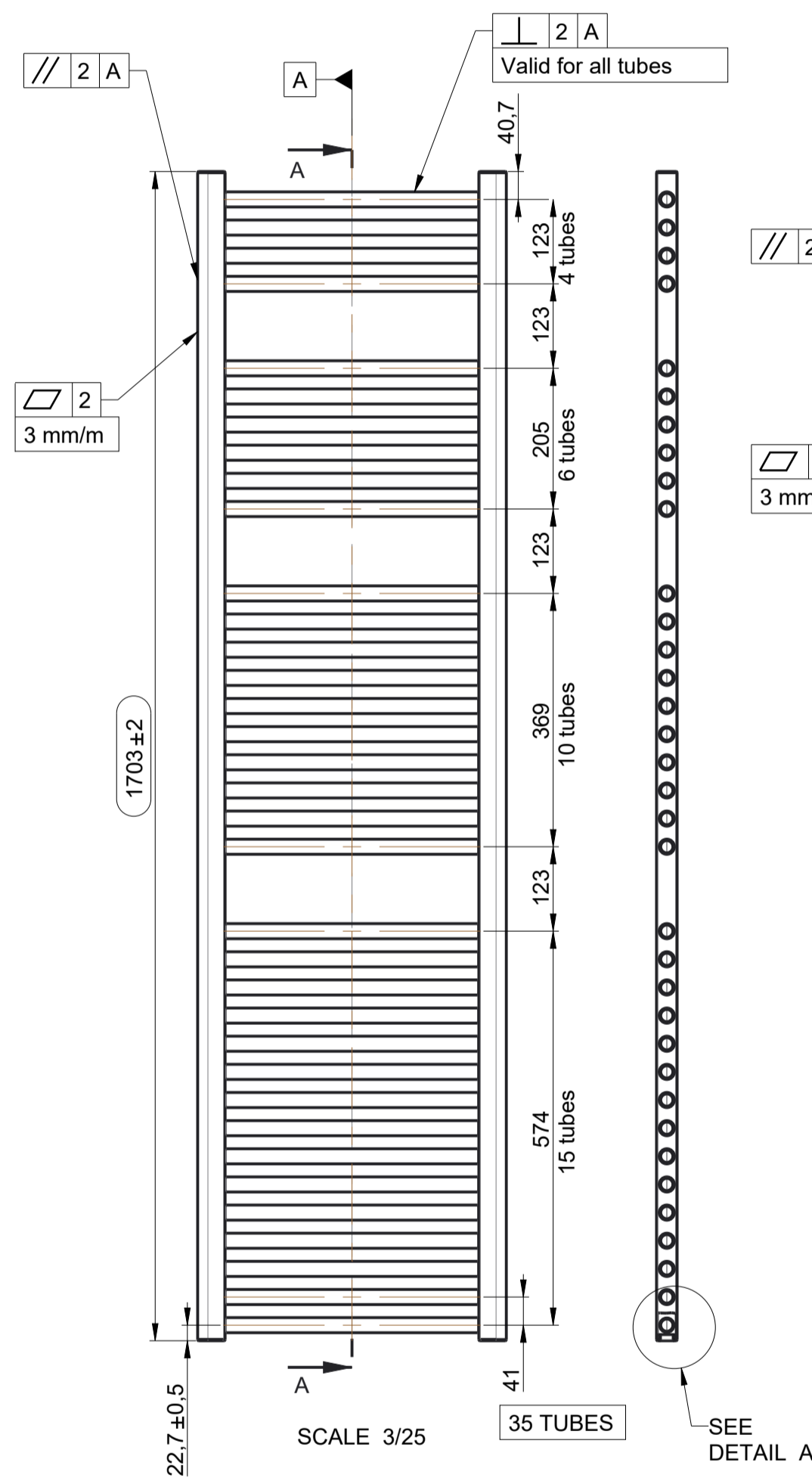

B	02.04.2019	Unite all Frame in one drawing	-	-	htunc
A	28.04.2015	Creation of drawing	-	-	muraty
Ind	Date	Modification	Modif/Demand	Modif by	
		Weight:	Material:		
Code: SR_DR_range		drawn by: stgizmr	checked by: mgays	status:	ERP ID: U0548476
creation date: 13/09/2018		SANREMO dritto - Gamma SANREMO straight - Range SANREMO gorade - Auswahl		PLM ID: U0548476	folio: 1 / 1
size: A2	scale: 1/5	This drawing can't be, without authorization, neither copied, neither reproduced, or communicated to thirds. Law of July 14, 1909 on the drawings and the models.			