

MFH

MODULAR. FLOOR HEATING. 20 mm.
INSTALLATION.

VarioComp.

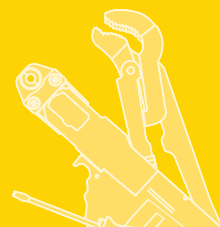
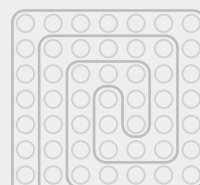
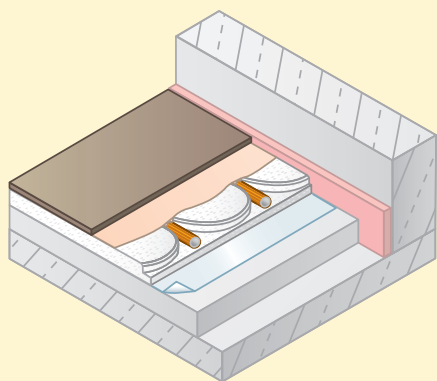
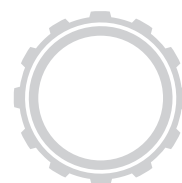

PDF

1. Safety information	3
1.1 General.....	3
1.2 Guarantee conditions	3
1.3 VarioComp panel storage/handling	3
1.4 VarioComp filling compound storage	4
1.5 Storage of VarioProFile pipe 11.6x1.5 Laser	4
1.6 System height tolerance.....	4
1.7 Coordination of floor construction	4
1.8 Standards.....	4
2. Preparation	5
2.1 Tools.....	5
2.2 Rooms	6
2.3 Vapour barrier/vapour retarder	6
2.4 Edge insulation strip	6
2.5 Movement joints	7
3. Substructure	8
3.1 General.....	8
3.2 Prerequisites as a suitable substructure	8
3.3 Examples of floor constructions	9
3.4 Insulation/impact sound protection/base panels directly below the VarioComp.....	10
4. VarioComp.....	11
4.1 PE construction foil	11
4.2 VarioComp panel / blank panel.....	11
4.3 VarioProFile pipe 11.6x1.5 Laser	12
4.4 VarioComp filling compound.....	16
5. Floor covering	18
5.1 General.....	18
5.2 Residual humidity of the VarioComp filling compound.....	18
5.3 Borders between VarioComp panels and blank panels (at bonding of floor coverings)	18
5.4 Levelling out with a calcium sulphate floor levelling compound	18
5.5 Compound sealing in rooms exposed to high humidity.....	19
5.6 Stone and ceramic coverings.....	20
5.7 Linoleum, carpet, PVC floor covering and synthetic resin floors	20
5.8 Wood covering, parquet and laminate	21
6. Protocols	22
6.1 Leak-tightness test in accordance with DIN ÖNORM EN 1264-4.....	22
6.2 Commissioning.....	22

1.1 General

These installation instructions are intended for authorised specialist personnel.
Observe the applicable local regulations and standards for electrical and heating installations.

1.2 Guarantee conditions

If the heating system is installed or commissioned incorrectly, all claims on the basis of the manufacturer's warranty and guarantee become void. Our currently applicable installation instructions are an integral part of our guarantee!

1.3 VarioComp panel storage/handling

The VarioComp panel is a milled 18 mm gypsum fibre panel and is delivered on pallets. When storing the VarioComp panel pallets, observe the load-bearing capacity of the place where they are being stored.

A single panel weighs 10.8 kg (50 pcs. / pallet)

The VarioComp panels should always be stored flat on an even surface. They should be protected from moisture, particularly rain. Panels that have become damp for a short time should only be used after they have completely dried out.

Always store the VarioComp panels with the naps facing upwards.

Here's how one person can lift a **single** VarioComp panel in the correct way:



Here's how two people can lift **several** VarioComp panels (5 panels and more) in the correct way:



First lower the VarioComp panels onto one edge and then lower them completely. Vertical storage leads to deformation of the panels and damage to the edges. It is possible to transport the panels horizontally inside the building with a lift truck or other panel transportation vehicle.



1.4 VarioComp filling compound storage

VarioComp filling compound is supplied on pallets in sacks weighing 25 kg. Ensure dry storage in shrink wrap until processing. Maximum storage time is 12 months.

1.5 Storage of VarioProFile pipe 11.6x1.5 Laser

The VarioProFile pipe is an aluminium multi-layer composite pipe (100 % oxygen diffusion-tight).

Damage (e.g. denting and scratching) is to be avoided during storage, transport, unloading, unwinding and laying. This type of damage has a detrimental effect on the creep behaviour.

In order to prevent damage to the VarioProFile pipe during the construction phase, high-visibility warning signs should be placed at appropriate locations.

The interaction of the air's oxygen with UV rays damages the pipes, which should not be stored in the open air. Normal temporary storage on the construction site for a few days is permissible.

At low temperatures ($\leq 5\text{ °C}$) the VarioProFile pipe should be stored in heated rooms prior to processing.

1.6 System height tolerance

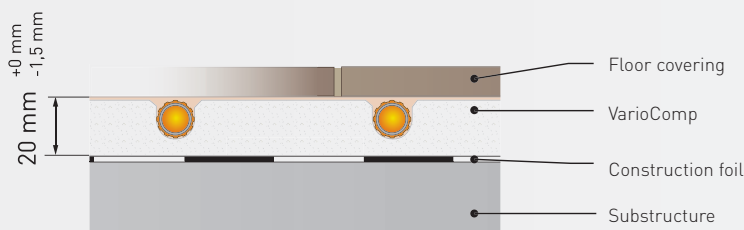

1.7 Coordination of floor construction

The following items must be coordinated between the architect, construction manager, installation technician and floor layer:

- Horizontal marking
- Floor construction with:
 - Strength appropriate to the level of use
 - Necessary vapour retarders/barriers
 - Necessary thermal insulation/impact sound insulation
- Expansion joints
- VarioComp filling compound to be applied by installer, floor layer or construction manager
- Floor covering, with heat sensors if necessary

The installation technician must coordinate or notify others of these discussions as per ÖNORM B 2242-1.

1.8 Standards

The validity of the standards specified in these installation instructions was last verified on 11 April 2016!

If necessary, amendments to standards must be checked!



2.1 Tools

Variotherm tools for mixing and applying the VarioComp filling compound:



Bucket set: 10 litre water bucket and 30 litre mixing bucket

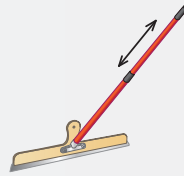

Scraper

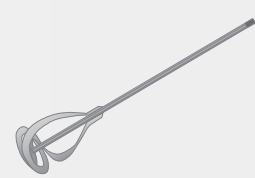

VarioComp mixing tool

Variotherm tools for connecting the Variotherm pipes:



Pipe cutting pliers



Calibration and chamfering tool

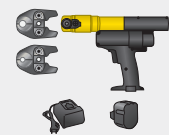
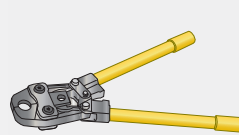

EcoPress or AkkuPress Mini pressing tool, incl. press-fitting jaws (e.g. for residual pipes)

Additional tools that are required/recommended for installation work:



Vacuum cleaner

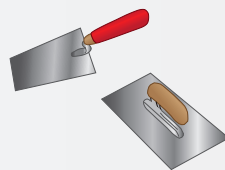

Trowel & plastering knife for cleaning

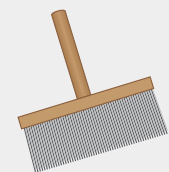

Brush or paintbrush for cleaning



Agitator for VarioComp filling compound

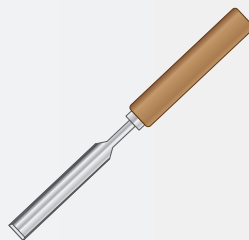

Woodworking chisel

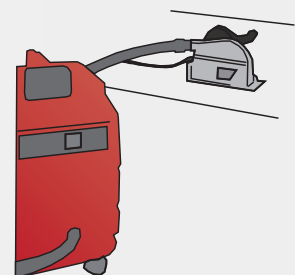

Circular saw with vacuum attachment or jig saw

2.2 Rooms

- The rooms must be cleared out, clean and dry. Residual plaster and mortar must be removed.
- During laying work, no other tradespersons may be working in the rooms.
- To prevent the VarioComp filling compound from drying out too quickly, there must be no draughts on the construction site (windows, exterior doors and door frames should be installed).

2.3 Vapour barrier/vapour retarder

Depending on the installation situation and the floor covering, either vapour barriers or vapour retarders must be installed in the floor structure. The necessity of these intermediate layers must be agreed upon in a coordination meeting between the contractors (construction company, installation technician, etc.).

2.4 Edge insulation strip

The edge insulation strip is adhered to the adhesive strip that runs around the exterior walls, as well as columns, steps, door frames, pillars, shafts etc. before the floor heating is laid. The edge insulation strip must permit movement of the floor heating of at least 5 mm.

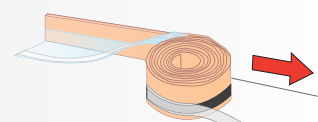

- The edge insulation strip should reach from the load-bearing subsurface (or the lower edge of the top insulation) to the upper edge of the covering.
- If this is not possible due to the construction, the edge insulation strip must at least reach from the lower edge of the VarioComp panel to the upper edge of the covering.

The foil of the edge insulation strip is stuck to the construction foil which is laid at a later stage using the adhesive strip.

After the upper covering has been completed, the protruding remainder of the edge insulation strip is removed (by folding down).

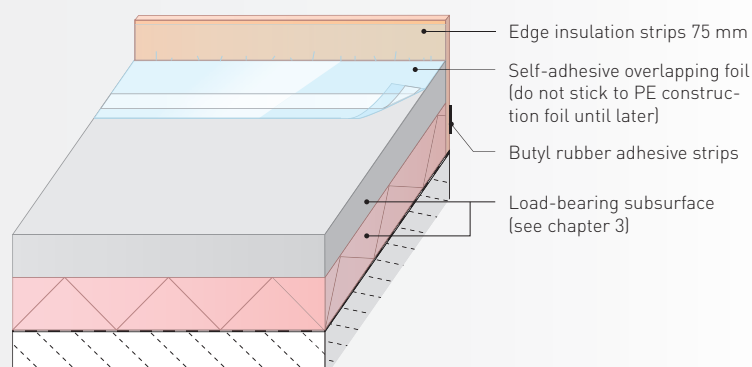

2.5 Movement joints

Movement joints (e.g. with edge insulation strips) are attached to provide tension-free accommodation of length alterations. These are to be defined by the architect or planner.

- Max. section size 80 m², max. edge length 12 m
- Keep the number of pipe feed-throughs through the movement joints as small as possible

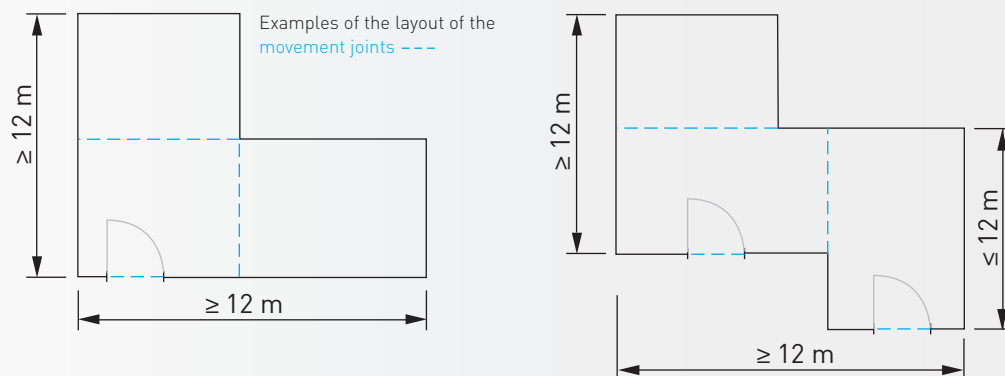

The movement joints are particularly important in the case of ceramic coverings. It is crucial that the movement joints run congruently in all layers (VarioComp floor heating and floor covering).

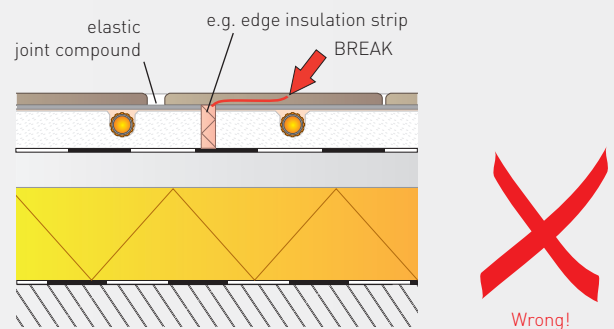
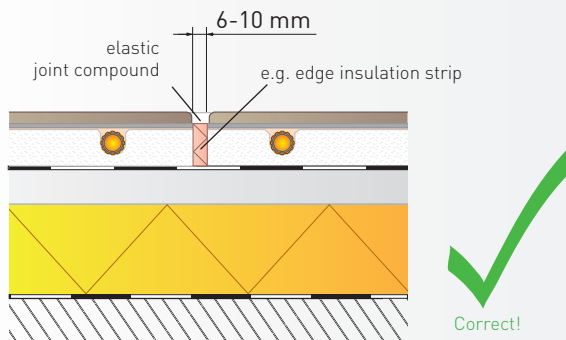

>> For details on pipe laying with movement joints, see chapter 4.

3.1 General

The VarioComp panel is purely a pipe bracket and thermal conduction element. The necessary static support, heat and impact sound insulation and protection against moisture diffusion must already be provided by the construction underneath the VarioComp panel. The rooms must be cleared out, clean, grease-free, dust-free and dry. Residual plaster and mortar must be removed.

All professional installers carrying out subsequent work must be informed of the floor heating installation in order to avoid damage. You can hang an information sign at an appropriate place in the construction site – available from www.variotherm.at (Service/Info centre). >>



3.2 Prerequisites as a suitable substructure

The substructure must be checked by the planner for suitability! Furthermore, coordination should take place between all trades involved regarding the overall progress of construction work, including follow-up work.

1. DRY	2. LEVEL	3. LOAD-BEARING																
<p>The subsurface must be dry, dust-free and grease-free. Maximum residual humidity of the subsurface (CM values):</p> <ul style="list-style-type: none"> • Untreated concrete: 3.0 % • Cement screed: 2.0 % • Calcium sulphate screed: 0.5 % 	<p>The required evenness is as follows (ÖNORM DIN 18202):</p>	<p>Calculation of load-bearing capacity:</p>																
<table border="1"> <thead> <tr> <th colspan="4">Measuring point spacing</th> </tr> <tr> <th>0.1 m</th> <th>1 m</th> <th>4 m</th> <th>10 m</th> </tr> </thead> <tbody> <tr> <td>1 mm</td> <td>3 mm</td> <td>9 mm</td> <td>12 mm</td> </tr> <tr> <td colspan="4">Max. pitch</td> </tr> </tbody> </table>	Measuring point spacing				0.1 m	1 m	4 m	10 m	1 mm	3 mm	9 mm	12 mm	Max. pitch					
Measuring point spacing																		
0.1 m	1 m	4 m	10 m															
1 mm	3 mm	9 mm	12 mm															
Max. pitch																		

The load-bearing capacity specified in the table below must be provided. If there are several concentrated loads, these must be at least 500 mm apart.

Caution: The sum of the concentrated loads must not exceed the maximum permissible floor load capacity. Particularly heavy objects (pianos, aquariums, bathtubs) must be given special consideration!

Room usage examples in accordance with ÖNORM EN 1991-1-1	Max. concentrated load Q_k	Max. service load q_k	Max. deformation V_m (with 100 kg on 100 x 100 mm)
<p>Category A1: Floors of rooms in residential buildings and houses, wards and hospital rooms (without heavy diagnostic instruments), rooms in hotels and lodgings, kitchens, toilets and rooms with residential-type use in existing buildings</p> <p>Category B1: Office floors in existing buildings</p>	2.0 kN	2.0 kN/m ²	1.5 mm
<p>Category B2: Office floors in office buildings</p> <p>Category C1: Floors in rooms with tables etc., e.g. classrooms in schools, cafés, restaurants, food halls, reading rooms, reception rooms, wards and hospital rooms (with heavy diagnostic instruments)</p>	3.0 kN	3.0 kN/m ²	1.0 mm
<p>Category C2: Floors in rooms with fixed seating, e.g. in churches, theatres, cinemas, conference rooms, lecture halls, meeting halls, waiting rooms, train station waiting rooms</p>	4.0 kN	4.0 kN/m ²	(Floor structure on request)

3.3 Examples of floor constructions

- The following examples are a selection of options, and do not necessarily represent the full scope!
- The subsurface must meet the criteria listed in chapter 3.2!

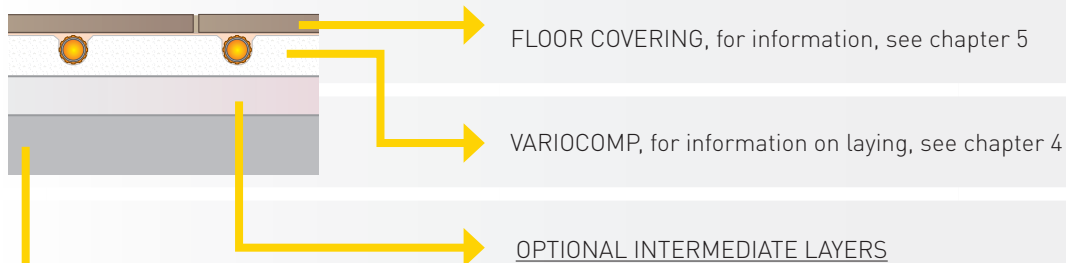

A. Thermal insulation/impact sound insulation

$d \leq 20$ mm with compressive strength 200 kPa [20 t/m²] with 10% compression

$d \leq 30$ mm with compressive strength 300 kPa [30 t/m²] with 10% compression

For product examples, see chapter 3.4



B. Thermal insulation/impact sound insulation

$d > 30$ mm or compressive strength < 200 kPa [20 t/m²] with 10% compression

Load distribution layer (L) necessary, e.g.:

- 18 mm OSB panel, tongue and groove bonded
- 19 mm chipboard (V100) tongue and groove bonded
- 25 mm dry screed element, processing according to manufacturer's instructions
- 2 x 15 mm OSB panel, adhered and screwed
- 2 x 19 mm chipboard (V100), adhered and screwed

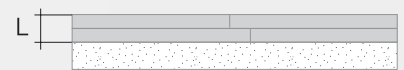

C. Fill

- Loose fill (note required compaction) e.g. Europearl®: Thermo-Plan® + Thermo-A8+ (Info sheet re. tested complete structure available on request!)
- Bonded fill (dry pipe density 350 kg/m³, compression strength 0.4 – 0.5 N/mm²)
- Trickle protection sheet, if required

Load distribution layer (L) necessary, e.g.:

- 20 mm dry screed element, processing according to manufacturer's instructions
- 2 x 15 mm OSB panel, adhered and screwed
- 2 x 19 mm chipboard (V100), adhered and screwed

SUBSURFACES

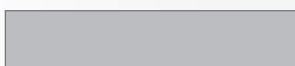

Screed:

- Test for evenness, and if necessary, even out using levelling compound/fill.
- Test for dryness.



Wood beam ceiling:

- Test bending, surface evenness and load-bearing capacity. (See e.g. max. deformation V_m , chapter 3.2)

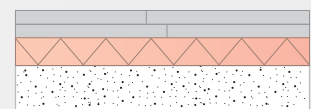

Dry structure

- Test for evenness and load-bearing capacity, and if necessary, even out using levelling compound.

Bare slab:

- Test for evenness, and if necessary, even out using levelling compound/fill.
- Building sealant, if required.

Note: 0.1 N/mm² = 100 kN/m² = 10 t/m² = 100 kPa; 1 kN ≈ 100 kg

3.4 Insulation/impact sound protection/base panels directly below the VarioComp

Selection of panels which can be laid directly below the VarioComp (insulation thickness max. 30 mm, see chapter 3.3):

Panels with **insulation max. 20 mm, compression strength 200 kPa (20 t/m²) at 10 % compression**

(Room usage A1/B1 according to table chapter 3.2)

Panels with **insulation max. 30 mm, compression strength 300 kPa (30 t/m²) at 10 % compression**

(Room usage A1/B1 + B2/C1 according to table chapter 3.2)

Insulation panels and base panels

Styrodur 2800C

Austrotherm Universal Construction Board / Uniplatte

DOW Styrofoam LB-A/LBH-X/RTM-NC-X, Floormate 200-A

Unifloor Jumpax CP/Heat-Pak

Jackon Jackodur CFR 300

Variotherm XPS-Platte 10-200 (10 mm)

Styrodur 3035CS

Austrotherm XPS Top 30

Foamglas T4+

DOW Floormate 500-A, Styrofoam LB-A/LBH-X/RTM-NC-X

Kingspan Styrozone H 350 R

Jackon Jackodur CFR 300

Unifloor Jumpax CP/Heat-Pak

XPS panels with plastered weave on both sides

Wedi Bauplatte

Jackon Jackoboard

PCI (BASF) Pucidur

Wedi Bauplatte

Jackon Jackoboard

PCI (BASF) Pucidur

Wood fibreboard

Steico Universal/Underfloor

Pavatex Isolair L22

Gutex Multiplex-top

-

Impact-sound insulation panel

Ceresit/Cimsec CL58 Multi-purpose insulating-board

Murexin Unitop

Ardex DS 40

PCI (BASF) Polysilent

Unifloor Heat-Foil/Redupax/Redupax+

Variotherm XPS panel 10-200 (10 mm),
(sound impact improvement 14 dB, measured on a 140 mm thick, bare reinforced concrete floor, MFPA Leipzig)

Ceresit/Cimsec CL58 Multi-purpose insulating-board

PCI (BASF) Polysilent

Unifloor Redupax+

4.1 PE construction foil

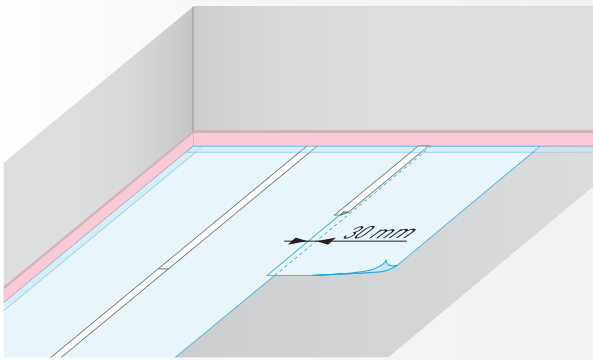

The construction foil is laid in its entirety over the load-bearing sub-surface with an overlap of 30 mm and fastened with adhesive tape. The load-bearing subsurface must be dust-free in order to prevent later unevenness of the VarioComp panels.

Note: If the VarioComp panel is positioned under gypsum fibre dry screed, no construction foil is needed.

In the edge areas, the construction foil is stuck to the overlapping foil of the edge insulating strip (self-adhesive strip). >>

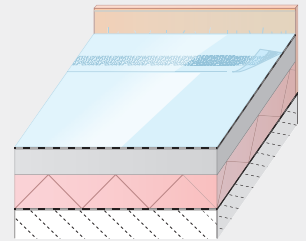

4.2 VarioComp panel / blank panel

- While laying the **VarioComp panels** the relative air humidity may not exceed the average daily level $\varphi = 70\%$.
- The load-bearing subsurface (according to chapter 3) must be cleaned, dust-free and dry.
- The area in front of the heating distribution manifold is left free because of the supply pipes (pipes are close together). The 11.6/77 VarioBar can be attached to fix the supply pipes in place.
- The VarioComp panels are laid lengthways or crossways, with an offset of at least 200 mm, edge to edge.

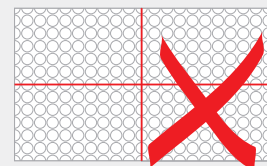
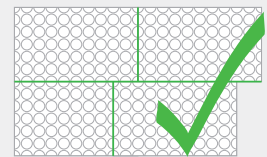
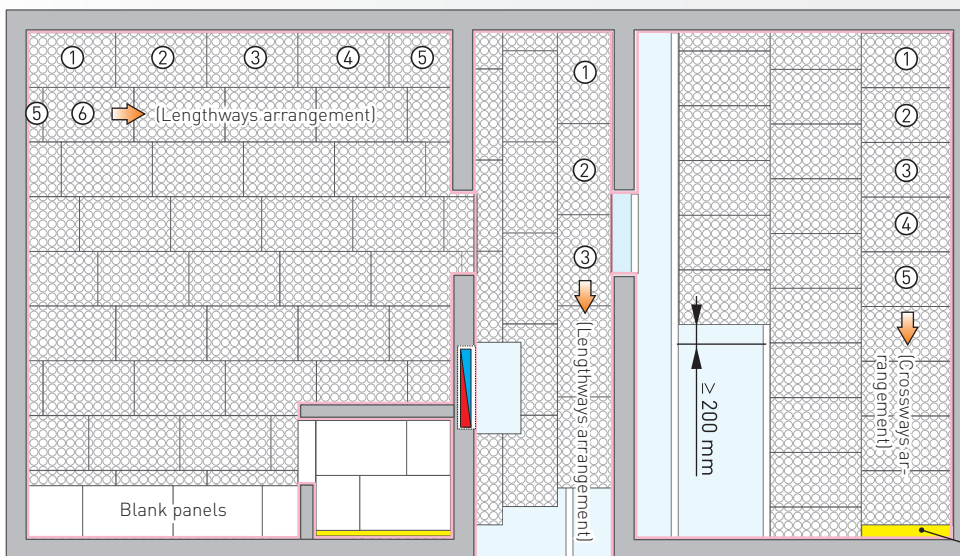
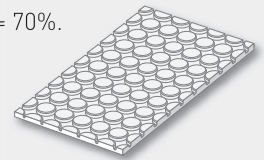

Small areas that are left out can be filled in with VarioComp filling compound, see chapter 4.4.

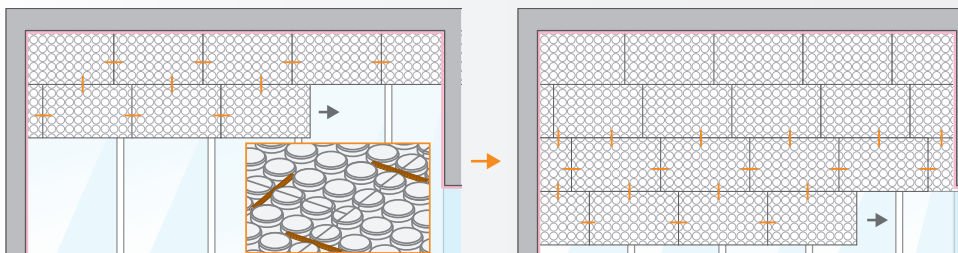

<< **A tip from Variotherm:** Align the rows of naps with approx. 200 mm long pipe pieces!

- The **blank panels** are used for small unheated surfaces instead of the VarioComp panels, e.g. pantry or fixed installed surfaces.

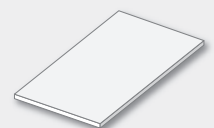

4.3 VarioProFile pipe 11.6x1.5 Laser

4.3.1 General

The VarioProFile pipe is placed between the naps of the VarioComp panels at a spacing of 100 mm or 200 mm.

200 mm spacing is not suitable for living rooms or barefoot areas!

Pipe length requirements at 100 mm spacing: 10 m/m², at 200 mm pipe spacing: 5 m/m². As a guide, there are markings on the VarioProFile pipe after each metre.

IMPORTANT: Maximum pipe length per heating circuit including supply pipes: 80 m (pay attention to the pump design!).

4.3.2 Laying patterns

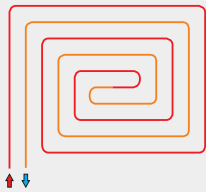

Bifilar

Uniform distribution of surface temperature as the supply is located next to the return.

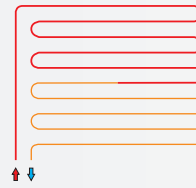

Meandering

Less uniform distribution of surface temperature, for small, ancillary rooms and peripheral zones.

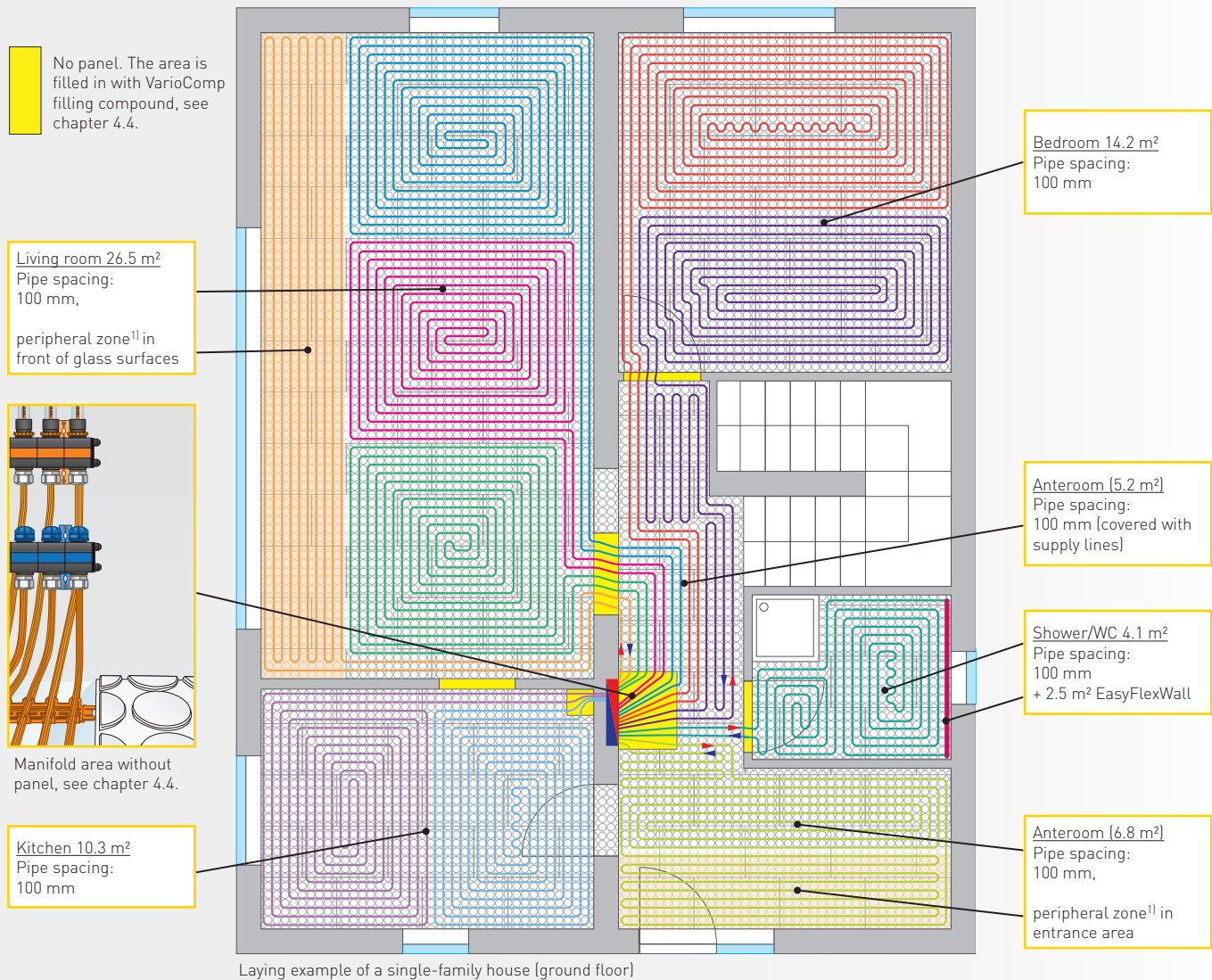

¹⁾ Peripheral zone: Starting in front of a large glass surface or glass doors, a meander pattern layout goes along the glass surface, reaching into the room by about 1 metre. This will lead to a higher surface temperature in front of the glass surfaces (Variotherm comfort tip).

4.3.3 Laying

Caution: Do not make any folds in the pipe! With a room temperature of over +5 °C, the pipes can be bent manually without pre-warming.

- Check that the grooves are clean!
- Lay without twisting, use a laying reel.
- Press the VarioProFile pipe between the routings using the sole of your shoe. When changing direction, guide the pipes around the routings with your thumb.
- After the heating circuit is completed, the VarioProFile pipe is returned to the heating manifold, cut off at the appropriate place, calibrated, and connected.

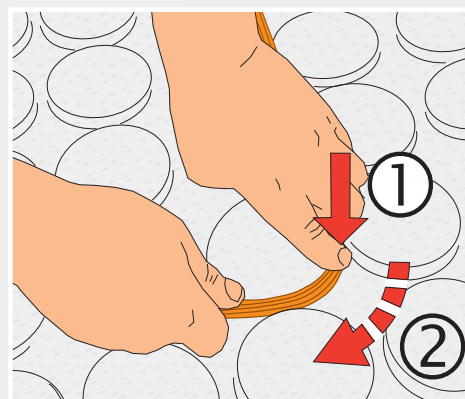
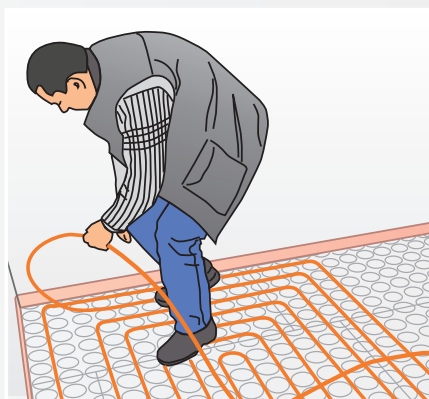
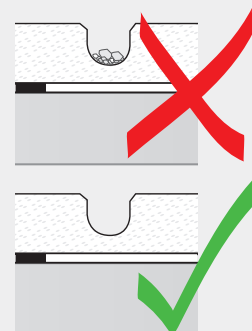

4.3.4 Pipe installation at movement joints

>> For preparation of movement joints, also see Section 2.

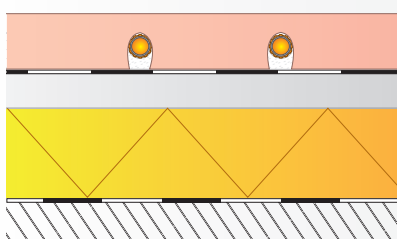

Pipe feed-through through the movement joint (no sleeve tube required)

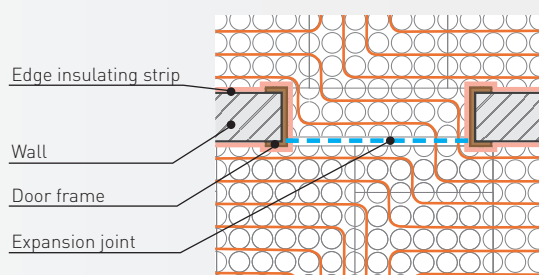

In the vicinity of the door, the expansion joint is fed through under the door leaf. Variant 1: Door area fitted with VarioComp panel

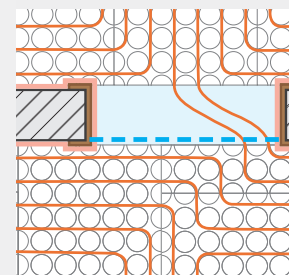

Variant 2: Later, only use VarioComp filling compound to fill in the door area.

4.3.5 Checks

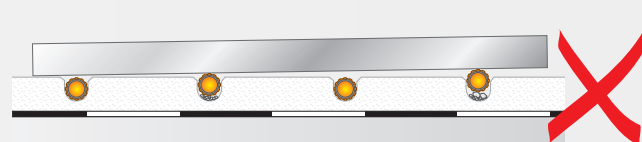
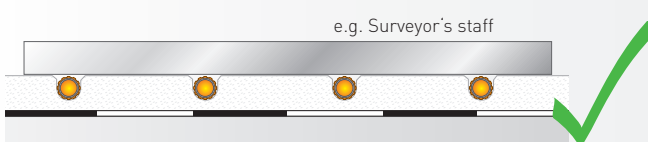

4.3.5 Cutting/calibration/press-fit connection

VarioProFile pipes can be joined in a permanent, non-detachable manner using a press-fit coupling connection in order to use residual lengths of pipe or for repairs.

Caution: A permanent, tight connection is only guaranteed if original Variotherm system components are used:

- VarioProFile pipe 11.6x1.5 Laser
- Variotherm calibration and chamfering tool
- Variotherm press-fit couplings and Variotherm pressing tool

Maintenance

The press-fitting jaws and pressing tool must be checked at least once a year for correct operation by REMS or an authorised REMS customer service workshop.

Preparing the pipe:

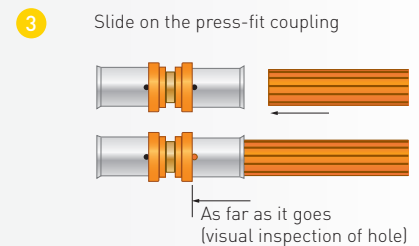
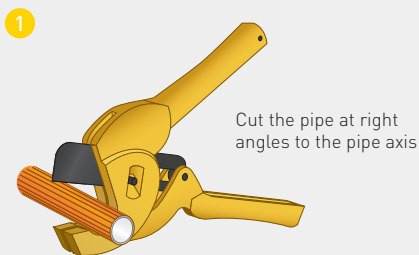

Pressing procedure for AkkuPress:

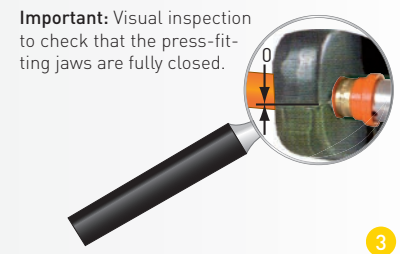
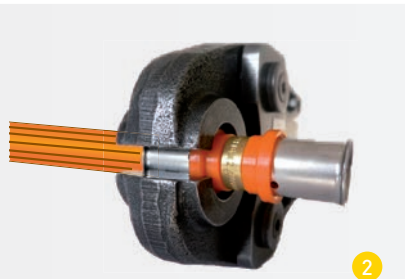
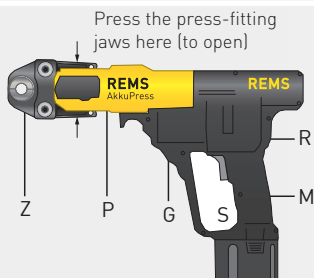

- Push the press-fitting jaws (Z) together by hand (causing the press-fitting jaws to open) far enough so that the press-fitting jaws can be placed over the press-fit coupling 2. Place the pressing tool with press-fitting jaws on the press-fit coupling at a right angle to the pipe axis.
- Release the press-fitting jaws so that they close around the press-fit coupling 3.
- Hold the pressing tool at the housing grip (G) and at the motor grip (M). When using an REMS AkkuPress, hold the switch (S) pressed until the press-fitting jaws are fully closed. This is indicated by an audible click.
- Press the reset lever (R) until the pressing rollers (P) have retracted completely. Press the press-fitting jaws (Z) together by hand so that the jaws can be removed from the press-fit coupling (see also the REMS AkkuPress operating manual).

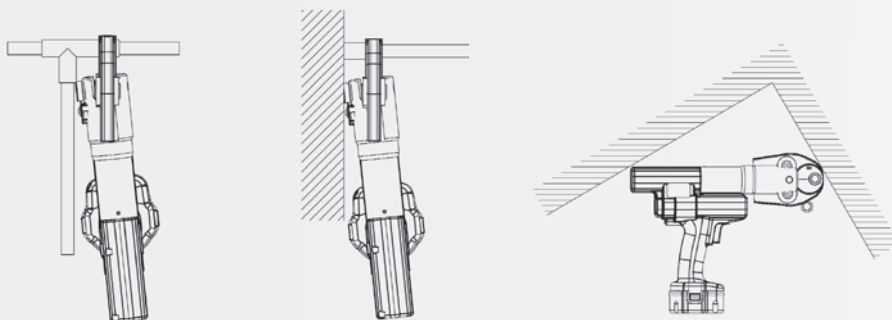

<< The following situations must be avoided (danger of gearbox breakage!)

Pressing procedure for Eco-Press:

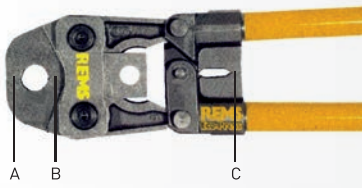

1

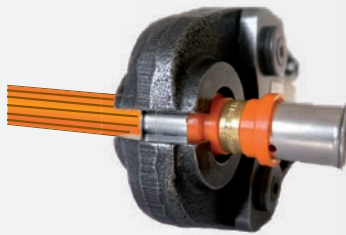

2

Important: Visual inspection to check that the press-fitting jaws are fully closed.

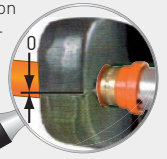

3

- The pressing tool's lever length can be adjusted to suit the pressing force and the available space on site. Use the provided pipe arms with sleeve sockets for extension. Always screw pipe arms tight before use (danger of accidents!). Secure the selected press-fitting jaws with plug-in bolts.
- Pull the pipe arms far enough apart (press-fitting jaws open) so that the press-fitting jaws can be slid over the press-fit coupling ②. Place the press-fitting jaws on the press-fit coupling at a right angle to the pipe axis.
- Push pipe arms together until they reach the stop position (C) (a click is heard when they reach the stop). Only if the press-fitting jaws are fully closed at (A) and at (B) has a correct press connection been carried out. > Visual check ③.
- Re-open the pipe arms so that the jaws can be removed from the press-fit coupling (see also the REMS Eco-Press operating manual).

Bei eventuell vorhandenen Pressverbindungen die Kompakt-Platte entsprechend mithilfe eines Holzstemmeisens ausstemmen. Die Pressverbindung muss komplett in der Kompakt-Platten Ebene liegen.

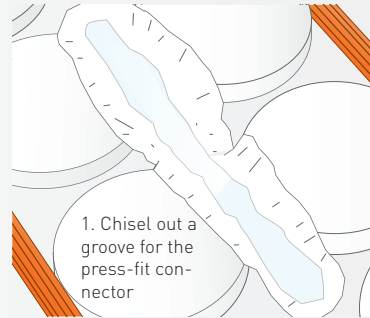
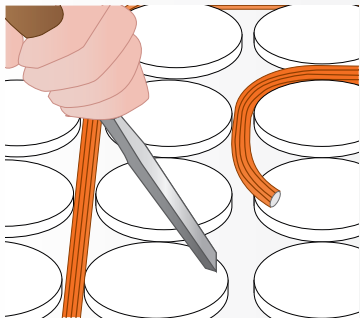

2. Insert the press-connected press-fit coupling and cut away the guide rings according to the illustration

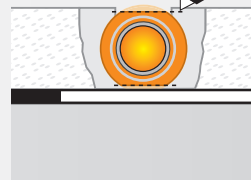

3. Cover with filling compound (see chap. 4.4)

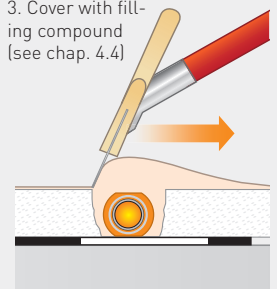

Corrosion prevention notice

The connecting elements are to be protected (after the pressure test) in accordance with ÖN H5155. For example, using cold shrink tape or corrosion protection tape.



4.3.6 Control and pressure test

Once all circuits have been connected to the heating/cooling manifold, the system can be filled downstream of the manifold and pressurised. The pipes are to be kept under water pressure prior to applying the VarioComp filling compound so that any damage becomes immediately visible.

Details regarding the system and heating circuit pipes and the room temperature control are provided in the "DISTRIBUTION and CONTROL" planning and installation instructions >>

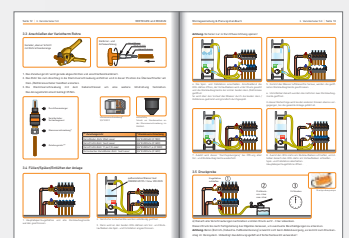

4.4 VarioComp filling compound

Before adding the VarioComp filling compound, a pressure test should be carried out for all the relevant heating circuits. Use the log for this purpose (chapter 6). We recommend that the VarioProFile pipes are kept under water pressure while adding the filling compound. The processing temperature must be at least +5 °C.

Manual application of the VarioComp filling compound (best with two people):

1 Fill 8 litres of cold water (+5 to 15 °C) with the water bucket into the mixing bucket.

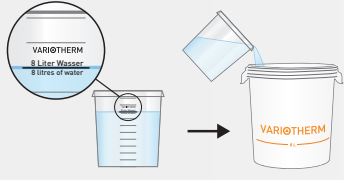

2 Add 1 bag of VarioComp filling compound (25 kg)
Consumption: 5.3 - 6.0 kg/m²



3 600 rpm
Mixing time: 1.5 - 2 min.

VarioComp mixing tool: for optimum processability of the VarioComp filling compound



4 Application of the VarioComp filling compound (not self-levelling)

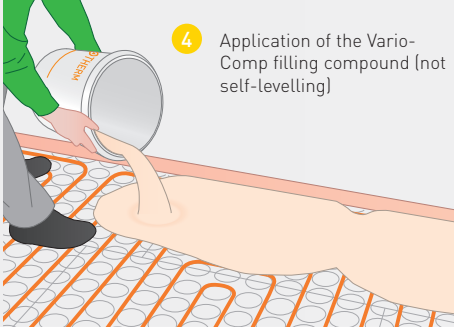

Pot life

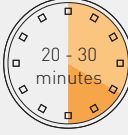

5



Scrape off at the level of the panels

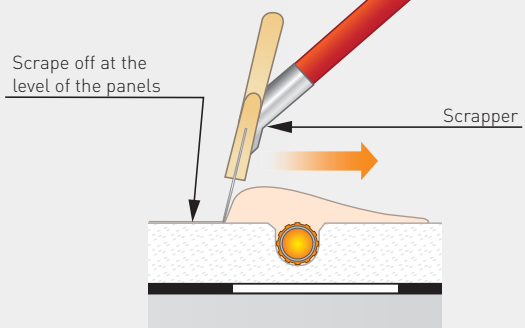

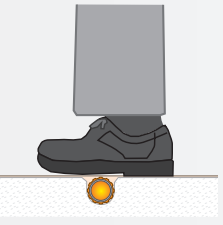

Scrapper

6

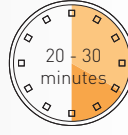

Can be walked upon after approx.
1.5 hrs. (t_i = 20 °C)
2.5 hrs. (t_i = 10 °C)

Pot life

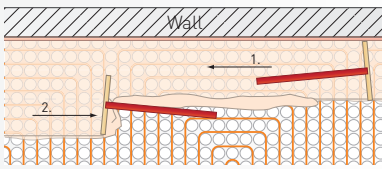

In order to prevent shortening of the pot life, empty the bucket completely after every mixing process with a trowel and clean it with a paint brush.

Mechanical application of the VarioComp filling compound:

The VarioComp filling compound can also be applied with a mixing pump (e.g. PFT G4, stator/rotor D6-3 PIN Twister with an agitator). The water quantity required is approx. 380 l/h.



Checking the applied VarioComp filling compound:

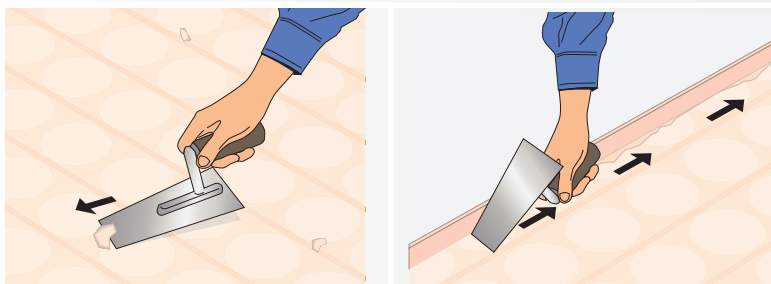

As soon as it is possible to walk on the surface, the excess filling compound is removed using a trowel or plastering knife.

Note: The soffit of the VarioProFile pipe is flush with the level of the panel surface and can be visible at several points!

Checks for the floor covering / filling depressions:



The surface of the VarioComp corresponds to the ÖNORM DIN 18202 (table 3, line 3), limits for levelness deviations (see also chapter 5).

Special case: If the standard tolerances according to the floor installer for the creation of the desired floor covering are too high, however, the recesses can be levelled out as follows:



Within 3 hours (at 20 °C) after adding the VarioComp filling compound a 2nd layer of VarioComp filling compound is applied.

25 kg VarioComp filling compound + 10 l water, approx. 0.5 kg/m² will be used.



After 3 hours have passed (at 20 °C) after adding the VarioComp filling compound the surface of the VarioComp system must be primed (for product examples see chapter 5.4). Then, the second layer of VarioComp filling compound is applied.

25 kg VarioComp filling compound + 10 l water, approx. 0.5 kg/m² will be used.

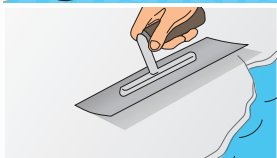

Depressions which go beyond the standard tolerances are filled in with floor levelling compound with a calcium sulphate base according to chapter 5.4.

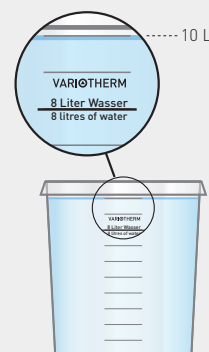

Applying the VarioComp filling compound in the manifold area:

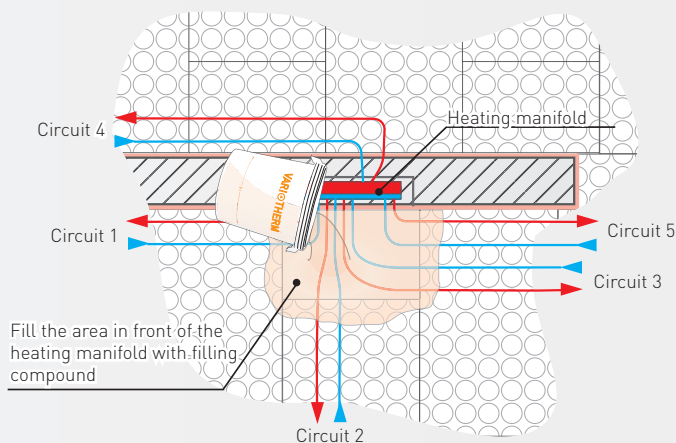
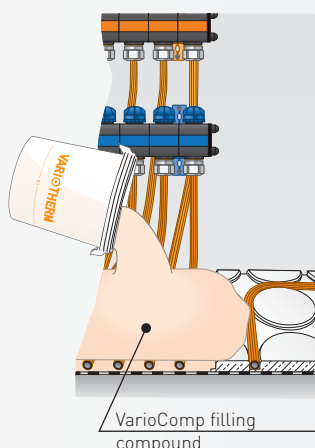
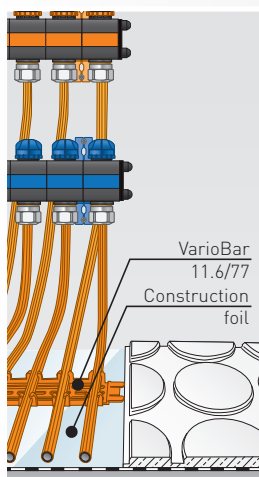

Fill the area in front of the heating manifold with filling compound

5.1 General

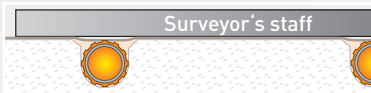

Measuring point spacing	0.1 m
Pitch max.	2 mm

- The floor covering used must be suitable for floor heating systems (observe the manufacturer's instructions).
- The surface of the VarioComp complies with ÖNORM DIN 18202 (Table 3, Row 3), limits for evenness deviations:

Caution: The floor covering should be laid as quickly as possible to avoid any soiling of the surfaces or damage to the pipes.

5.2 Residual humidity of the VarioComp filling compound

Before laying the floor covering, the VarioComp filling compound must be dried in accordance with the following table:

Floor covering (Take note of the manufacturer's instructions!)	CM value (for measuring, remove 100 g of filling compound)	Drying time (estimated values at $t_i = 20\text{ °C}$)	
		without baking out	with baking out ¹⁾ at $t_v = 40\text{ °C}$
Stone & ceramic coverings in a thin bed	1.3 %	6 days	24 h
Wood covering, parquet	0.3 %	8 days	36 h
Linoleum, PVC, vapour-tight floor covering (floor-levelling compound already applied as per chapter 5.7)	0.3 %	not possible	≥ 48 h

¹⁾ At $t_i = 20\text{ °C}$, you must wait at least 2 hours after finishing applying the filling compound before beginning the baking out process.

5.3 Borders between VarioComp panels and blank panels (at bonding of floor coverings)

Cover the borders using glass fibre cloth (4 x 4 mm) at an overlap of 200 mm (e.g. bond using tile adhesive).

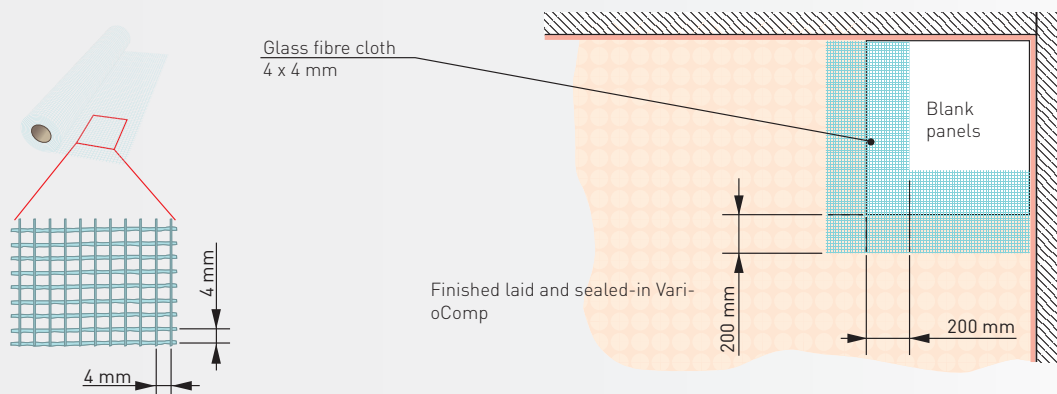

5.4 Levelling out with a calcium sulphate floor levelling compound

In the following cases, the finished VarioComp surface is additionally levelled with a calcium sulphate floor levelling compound:

- For soft floor coverings and synthetic resin floors (see chapter 5.7)
- Depressions which exceed the standard tolerances (see chapter 5.1) or which are too high for the floor covering according to the floor installer

Brand	Primer	Calcium sulfate floor-levelling compound
Mapei	Primer G	Planitex D10
Schönox	Schönox VD, PG	Schönox AP
Maxit	maxit floor 4716	maxit floor 4095
Fermacell	Deep primer	Self levelling compound
Thomsit	R766, R777	AS1, AS2
Stauf	IBOLA D54	IBOLA GS
Murexin	D7	CA 40
Baumit	Grund	Nivello Quattro
Smet	Universal Floor Primer	SHG Casufloor FS
Ardex	Ardex P51	Ardex K22



5.5 Compound sealing in rooms exposed to high humidity

For surfaces which are exposed to high levels of humidity, sealing systems must be applied (e.g. bathrooms with shower trays - W3).

The wall construction must be sealed using sealing system and additional sealing tape.

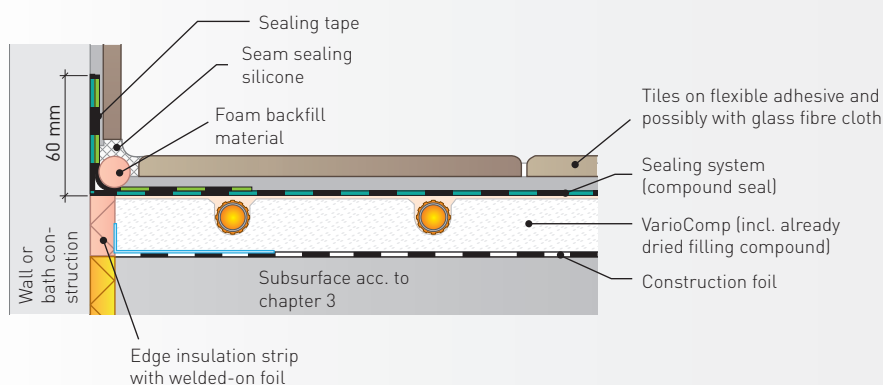

<< Example:

Tiled floor covering subject to the effects of moisture (W2/W3)
(More details for tiled covering on VarioComp see chapter 5.5)

Use of primer and sealing system (compound sealing):

Operational demands group		Which room?	Adhesive mortar with tile coverings	Primer	Sealing system
ÖN B 3407	ZDB composite waterproofing (Germany)				
W1	-	<u>Residential sector:</u> living rooms, corridors, toilets, offices and the like	Calcium sulfate flexible adhesive mortar	Not required	Not required
			Cement flexible adhesive mortar	Required	Not required
W2	-	<u>Residential sector:</u> kitchen and rooms with similar usage <u>Commercial sector:</u> toilet systems	Only cement flexible adhesive mortar	In addition to the sealing system, when recommended by the manufacturer	Recommended
W3	A0	Wall and floor surfaces without drainage (e.g. bathroom with shower tub), toilet systems without floor drainage, porch	Only cement flexible adhesive mortar	In addition to the sealing system, when recommended by the manufacturer	Required
W4 – W6	B0, A, B, C	Wall and floor surfaces with drainage (e.g. shower with flush drain at the same level as the floor), swimming bath area, shower systems, industrial kitchen, balconies, terraces,...	No VarioComp floor heating possible.		

Product examples for primer or sealing system (compound sealing):

Manufacturer / Brand	Primer	Sealing system
Ardex	Ardex P51	Ardex 8 + 9
Murexin	Tiefengrund LF1	Flüssigfolie 1KS
Cimsec	Gipsgrundierung / Haftbrücke	Dichtflex CL51 / 2K Abdichtung CL49
PCI (BASF)	Gisogrund	Lastogum
Schönox	Schönox KH	Schönox HA / 1K DS Premium
Mapei	Primer G	Mapegum WPS
Weber	weber.prim 801	weber.tec 822
Ceresit	Lösungsmittelfreier Tiefengrund CT17	Ceresit Dusch- & Badabdichtung
Sopro*	GD 749	Flächendicht flexibel FDF 525/527

*For more details, see the Sopro installation recommendations (available on request).

5.6 Stone and ceramic coverings

See also the appropriate standards for laying tiles, panels and mosaics..

- The surface must be dust-free.
- Sealing systems must be used on surfaces subject to the effects of moisture (see chapter 5.5).
The wall boundaries must be sealed using appropriate sealing tape.
- A flexible adhesive (S1 classified according to EN 12004) is used to bond the tiles. A primer must be applied if required by the adhesive manufacturer. This is particularly the case for flexible cement adhesives.
- Flexible grouting mortar must be used for grouting.
- After laying the tiles, boundaries with the walls are additionally sealed with silicone.

For critical floor structures, we recommend integrating a 4 x 4 mm fibre glass cloth into the flexible adhesive.

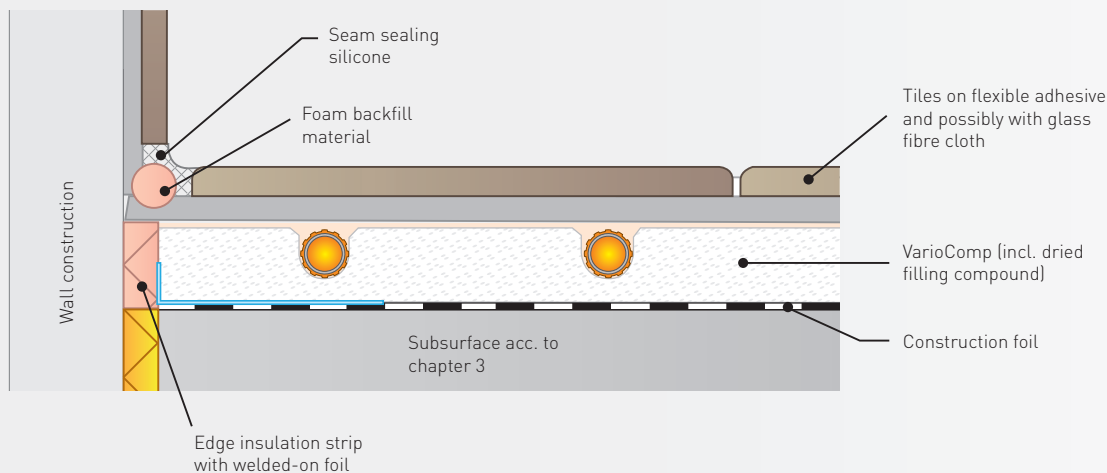

5.7 Linoleum, carpet, PVC floor covering and synthetic resin floors

For soft floor coverings and synthetic resin floors, a calcium sulphate-based floor-levelling compound (provided by customer) at least 4 mm thick is laid over the completed VarioComp (see chapter 5.4).

Caution: Only use synthetic resin floors with low thickening tension (polyurethane-based)!

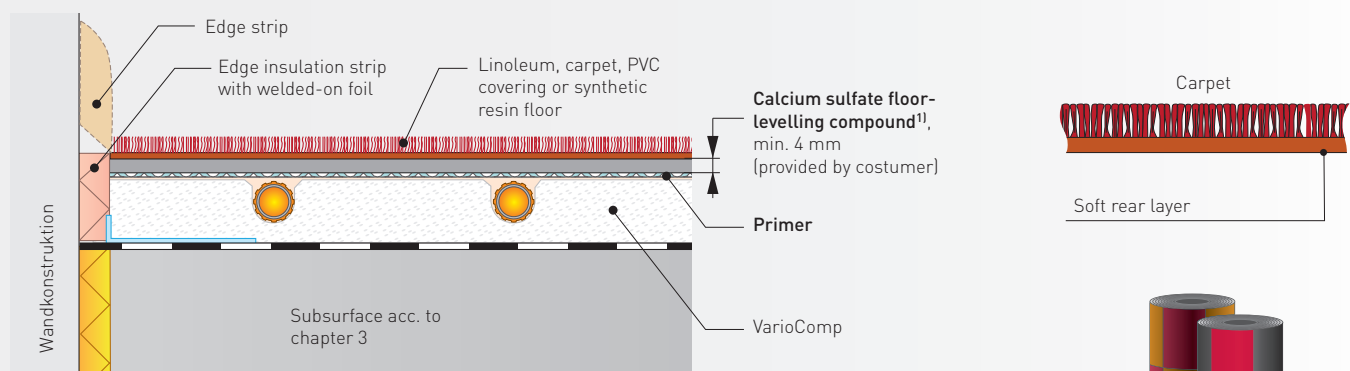

¹⁾ Please observe the relevant manufacturer's instructions for the required primer or sealant of the VarioComp surface and of the planned floor-levelling compound. Product examples see chapter 5.4.

Work cannot be started earlier than 48 hours after applying the VarioComp filling compound.

5.8 Wood covering, parquet and laminate

- **It is not necessary and prohibited to abrade the surface of the finished VarioComp!**
- Lay only floor coverings that are approved by the manufacturer for use with floor heating systems.
- We recommend a covering with a maximum thermal resistance of 0.15 m²K/W.

FLOATING APPLICATION:

- The laminate/parquet covering is laid floating on an underlay suitable for floor heating (max. 2 mm).
- The edge seam to adjacent components should be at least 10 mm.

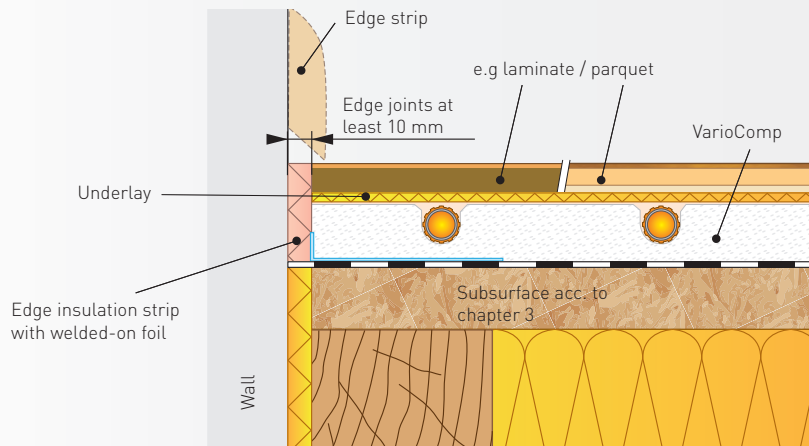

ADHESIVE PARQUET:

Parquet can be glued onto the VarioComp under the following conditions:

- 2 or 3 layer parquet suitable for floor heating, without gluing the tongue and grooves. It is prohibited to glue solid wood flooring!
- Maximum flow temperature 40 °C (Maximum temperature limiter required!)
- Gluing without primer using e.g.:
 - Mapei Ultrabond P990 1K / Eco P991 1K
 - Thomsit P695
 - Ardex Premium AF2420
 - Weitzer Parkett Profi-SMP Kleber Nr. 400-EC1
 - Sika SikaBond-52 Parquet und SikaBond-54 Parquet
 or equivalent adhesive (primer as per manufacturer's specifications).
- The parquet is glued either directly to the VarioComp system, or with decoupling fleece (observe the manufacturer's specifications!).

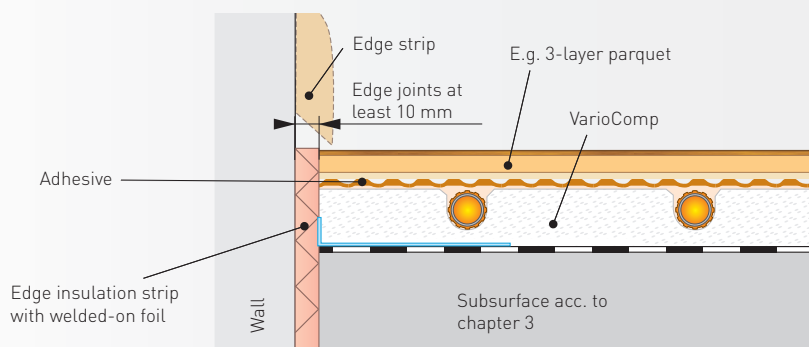

6.1 Leak-tightness test in accordance with DIN ÖNORM EN 1264-4

Construction project: _____

Building owner/Occupant: _____

Client: _____

Heating installation technician: _____

Architect: _____

Other: _____

The VarioComp floor heating system circuits are to be tested for leak-tightness using a water pressure test after they have been laid. The test pressure should be min. 4 bar and max 6 bar. If there is a risk of freezing, appropriate measures should be taken, e.g. use of antifreeze and controlling the building's temperature.

- Installation completion of the VarioComp panels including connections and piping on: _____
- Pressure test started on: ____ . ____ . ____ with test pressure of ____ bar
- Pressure test completed on: ____ . ____ . ____ with test pressure of ____ bar
- Einbringen der Kompakt-Füllmasse Beginn am: _____ Ende am: _____
- The system water was treated (e.g. as per ÖNORM H5195-1) Yes No
- Antifreeze was added to the system water Yes No
- The VarioComp has been baked out as described in chapter 5.2 with $t_f/t_r =$ ____ / ____ °C:
 No Yes: 24 h 36 h ____ h
- Floor covering: Tiles Parquet Carpet, linoleum Other _____
- Completing the laying work on: _____
- Baking out begin (max. flow temperature of the VarioComp floor heating $t_f = 50$ °C) on: _____

Approval:

Building owner/Occupant/Client

Construction management/Architect

Heating installation technician

6.2 Commissioning

Please note that the flow temperature (heating water) of the VarioComp floor heating may not exceed $t_f = 50$ °C. The main stop valves at the distributor station, and the heating circuit shut-offs are to be opened. The entire system is to be deaerated thoroughly. The circulation pump may be switched on after deaeration. After commissioning, the VarioComp floor heating system can be considered maintenance-free.

(Subject to technical modifications without notice.)

ENJOY THE COMFORT & SAVE ENERGY

That's why our customers love us:

Heating and cooling optimised for COMFORT in all rooms!

Fast and friendly service, ANSWERS backed up with expertise!

Always in tune with the latest technology, INNOVATION guaranteed!

Everything CLEAR and SIMPLE, in writing of course!

PROFESSIONALISM at all times, from the first contact to the reference list!

VARIOTHERM SINCE 1979

Variotherm is an Austrian model plant with hundreds of partners in Austria, Europe and around the world.

All rights pertaining to distribution and translation, in whole or in part, including film, radio, television, video recording, Internet, photocopying and reprinting, are reserved. Subject to mistakes and printing errors. Misprints and errors excepted.

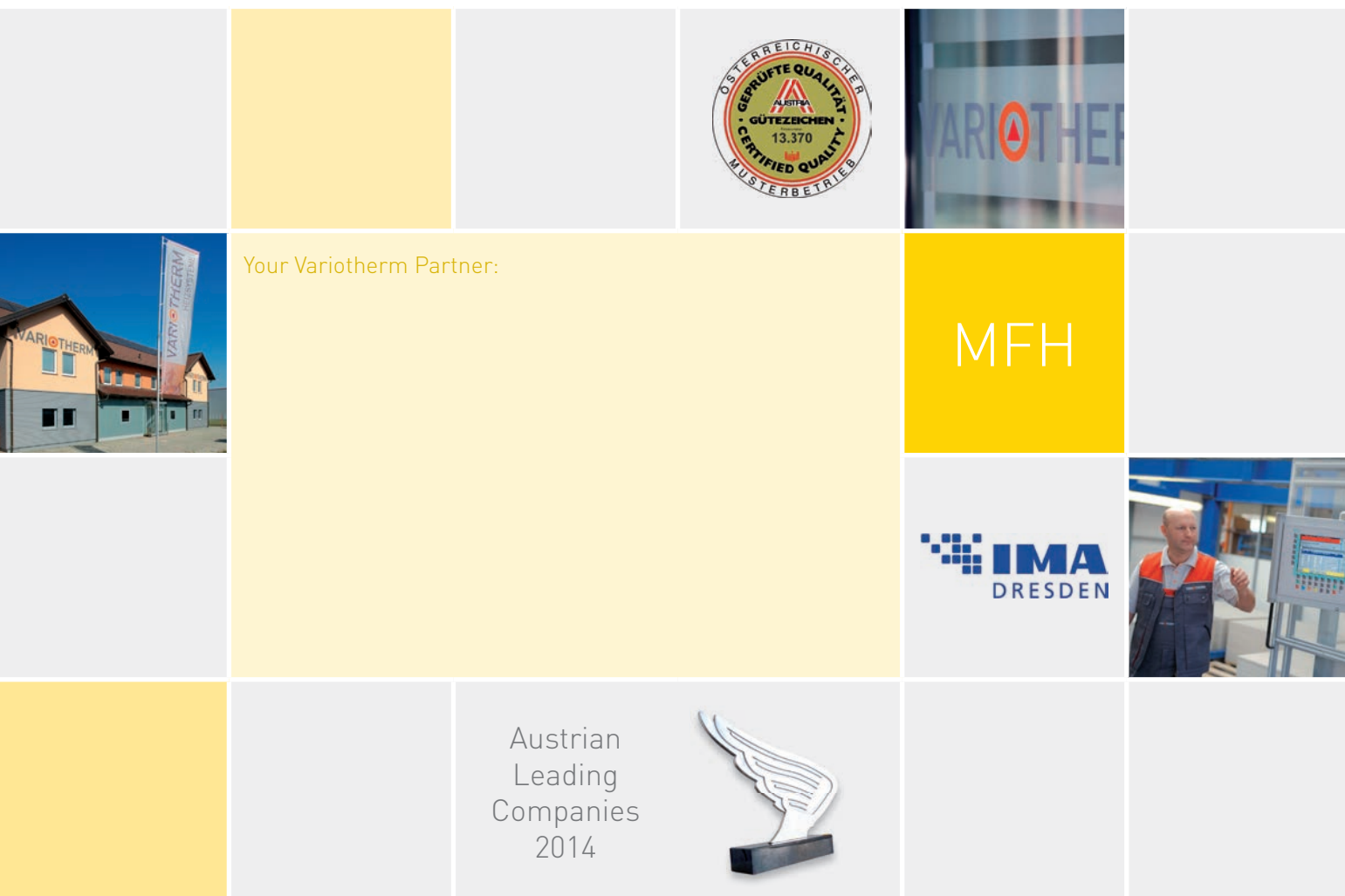

VARIOTHERM HEIZSYSTEME GMBH

GÜNSELSDORFER STRASSE 3A
2544 LEOBERSDORF
AUSTRIA

Phone: 0043 22 56 - 648 70-0

Fax: 0043 22 56 - 648 70-9

office@variotherm.at www.variotherm.com