

WALL BRACKETS

F7V SERIES QUICK-MOUNTING BRACKETS WITH ANTI-LIFT MECHANISM
VERSION FOR VERTICAL PANELS, INCLUDING SC6 ANTI-SLIDING SAFETIES

CODE

60630070T

Set of 2 F7VERT, including SC6 safeties,



25

300



N° B 15 01 68251



N° VA_MES 15 02 051

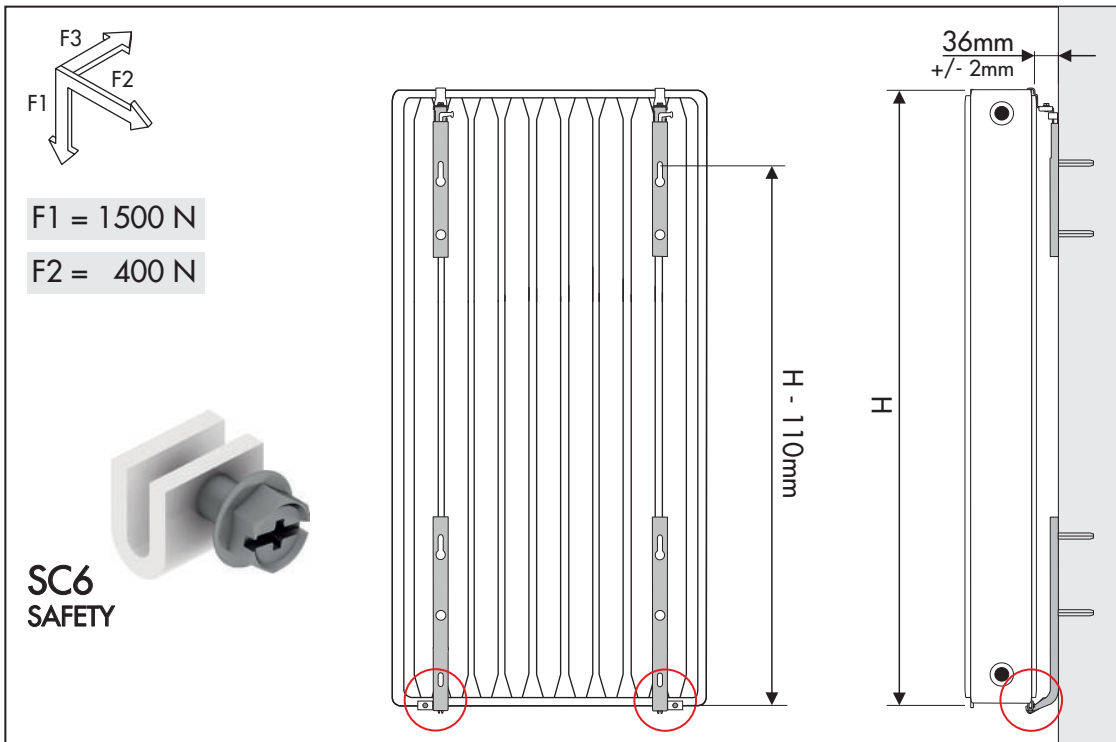
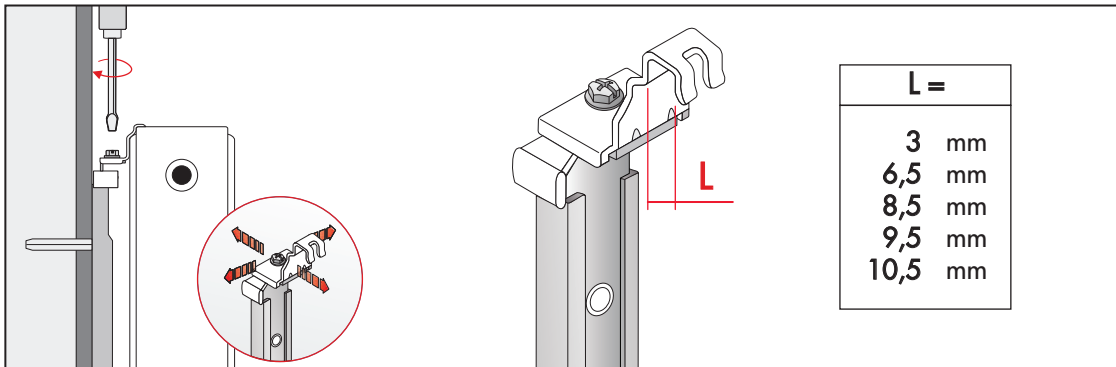
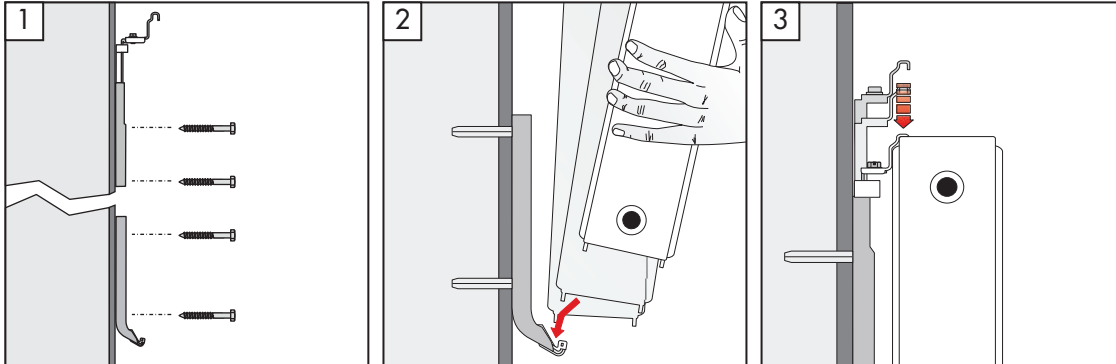

F7VERT

